

Globe Valves

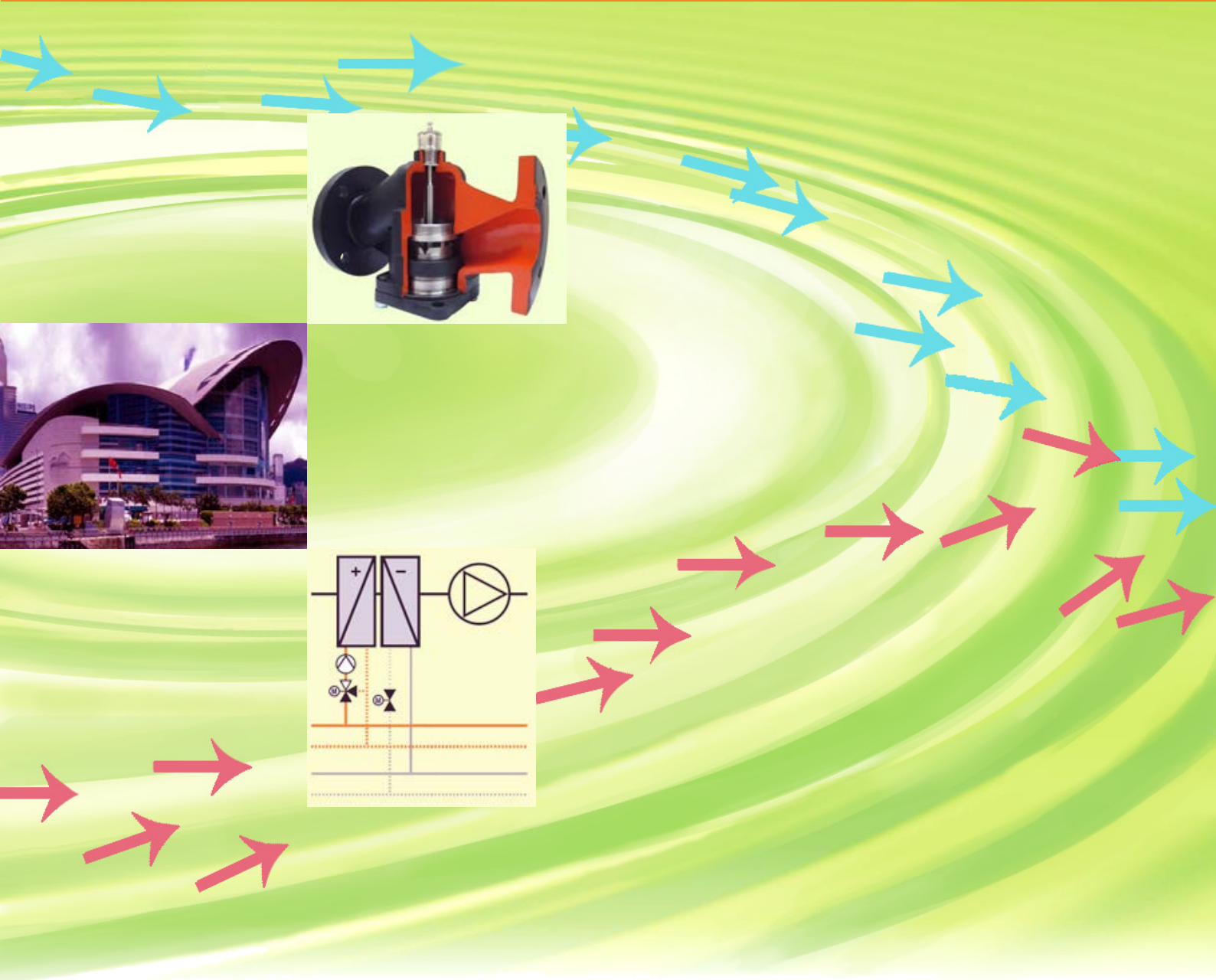

Technical Databook

Version 1.2



Globe Valves Product Overview	
Max. Close-off Pressure - Globe Valve Series	4
Globe Valve Actuators Product Overview	5
General Information	
Globe Valves	6
Globe Valve Actuators	7
Globe Valves	
H2..X-S, 2-way, with internal thread	8
H3..X-S, 3-way, with internal thread	11
H6..W-SP, 2-way, with flange PN16	14
H7..W-S, 3-way, with flange PN16	17
H7..W-D, 3-way, with flange PN16	20
Globe Valves Dimension Size Overview	22
Globe Valve Actuators, 1000N	
NV24A-TPC	24
NV230A-TPC	27
NV24A-SZ-TPC	30
NV24A-MP-TPC	33
Globe Valve Actuators, 1500N	
SV24A-TPC	39
SV230A-TPC	42
SV24A-SZ-TPC	45
SV24A-MP-TPC	48
Globe Valve Actuators, 2500N	
EV24A-TPC	54
EV230A-TPC	57
EV24A-SZ-TPC	60
EV24A-MP-TPC	63
Globe Valve Actuators, 4500N	
RV24A-SZ	69
RV24A-MF	72
Electronic Globe Valve Actuators, 1000N	
NVK24A-3-TPC	77
NVK230A-3	81
NVK24A-MP-TPC	85
Electronic Globe Valve Actuators, 2000N	
AVK24A-3-TPC	93
AVK230A-3	97
AVK24A-MP-TPC	101
Mounting Instructions	109

Max. Close-off Pressure - Globe Valve Series

AP Globe Valve					NV../NVK.. 1000N, 20mm			SV.. 1500N, 20mm			AVK..* 2000N, 32mm			EV.. 2500N, 40mm			RV.. 4500N, 40mm		
Types	DN (mm)	2-way	3-way	Kvs (m ³ /h)	ΔPs 2-way (bar)	ΔPmax 2-way (bar)	ΔPs ΔPmax 3-way (bar)	ΔPs 2-way (bar)	ΔPmax 2-way (bar)	ΔPs ΔPmax 3-way (bar)	ΔPs 2-way (bar)	ΔPmax 2-way (bar)	ΔPs ΔPmax 3-way (bar)	ΔPs 2-way (bar)	ΔPmax 2-way (bar)	ΔPs ΔPmax 3-way (bar)	ΔPs 2-way (bar)	ΔPmax 2-way (bar)	ΔPs ΔPmax 3-way (bar)
PN25 0-130°C Internal Screw	15	H2015X-S	H3015X-S	1.9	8	8	8												
	20	H2020X-S	H3020X-S	4.4	8	8	8												
	25	H2025X-S	H3025X-S	8	6	6	6												
	32	H2032X-S	H3032X-S	10	5.5	5.5	5.5												
	40	H2040X-S	H3040X-S	20	4.5	4.5	4.5	7	7	7									
	50	H2050X-S	H3050X-S	32	3	3	3	5	5	5									
PN16 0-150°C Flange	65	H6065W-SP	H7065W-S	50				16	10	4.5									
	80	H6080W-SP	H7080W-S/D	80							16	10	2	16	10	2.7	16	10	3.5
	100	H6100W-SP	H7100W-S/D	125										16	10	2	16	10	3
	125	H6125W-SP	H7125W-S/D	200										16	10	1.5	16	10	2
	150	H6150W-SP	H7150W-S/D	300										16	10	1	16	10	1.5
	200	H6200W-SP	H7200W-S	520													16	10	1.3
	250	H6250W-SP	H7250W-S	750													16	10	0.8

Non-fail Safe						
On/Off	AC/DC 24V	NV24A-TPC	SV24A-TPC			EV24A-TPC
	AC 230V	NV230A-TPC	SV230A-TPC			EV230A-TPC
Modulating	AC/DC 24V	NV24A-SZ-TPC	SV24A-SZ-TPC			EV24A-SZ-TPC
Multifunction		NV24A-MP-TPC	SV24A-MP-TPC			EV24A-MP-TPC
MP-Bus						RV24A-SZ
						RV24A-MF
Electronic Fail Safe						
3-point control	AC/DC 24V	NVK24A-3-TPC			AVK24A-3-TPC*	
	AC 230V	NVK230A-3			AVK230A-3	
MP-Bus	AC/DC 24V	NVK24A-MP-TPC			AVK24A-MP-TPC*	

* Only available through VC

ΔPmax is maximum permitted pressure difference for long service life across control path A-AB, referred to the whole range of opening.

ΔPs is closing pressure at which the linear actuator can still seal the valve tightly allowing for the appropriate leakage rate.

	1000N	1500N	2500N	4500N
New Generation Globe Valve Actuator	NV..A	SV..A	EV..A	RV..A
Open/Close, 3-point, AC/DC 24V, 50/60Hz	NV24A-TPC	SV24A-TPC	EV24A-TPC	
AC 230V, 50/60Hz	NV230A-TPC	SV230A-TPC	EV230A-TPC	
Modulating control signal DC (0)0.5-10V, Feedback DC (0)0.5-10V, 50/60Hz	NV24A-SZ-TPC	SV24A-SZ-TPC	EV24A-SZ-TPC	RV24A-SZ
Multifunction, MP-Bus, 50/60Hz Control signal variable DC (0)0.5-32V, Feedback signal variable DC (0)0.5-10V	NV24A-MP-TPC	SV24A-MP-TPC	EV24A-MP-TPC	RV24A-MF
Running Time	150s (variable on -MF and -MP)			
Stroke	20mm	20mm	40mm	40mm
Sound Power Level	Max. 55dB(A)	Max. 45dB(A)	Max. 55dB(A)	Max. 65dB(A)
Manual Override	Gear disengagement with push-button			
Electrical Connection	1m cable, -TPC (Terminal with 1m cable)			
Direction of Rotation	Selected by switch			
Position Indicator	Mechanical 5..20mm		Mechanical 5..40mm	
Degree of Protection	IP54			
EMC	CE in accordance with 2004/108/CE			
Certification IEC/EN	Certified to IEC/EN 60730-1, IEC/EN 60730-2-14			
Ambient Temperature	0°C..+50°C			
Non-operation temperature	-40°C..+80°C			
Ambient Humidity	95% r.h., non-condensing			

	1000N	2000N
Supercap Electronic Fail-Safe Actuator	NVK..A	AVK..A
3-point control AC/DC 24V, 50/60Hz	NVK24A-3-TPC	AVK24A-3-TPC
AC 230V, 50/60Hz	NVK230A-3	AVK230A-3
Multifunction, MP-Bus, 50/60Hz Control signal variable DC (0)0.5-32V, Feedback signal variable DC (0)0.5-10V	NVK24A-MP-TPC	AVK24A-MP-TPC
Running Time Standard Power off position	150s 35s	
Stroke	20mm	32mm
Sound Power Level Standard Power off position	55dB(A) 60dB(A)	60dB(A) 60dB(A)
Manual Override	Gear disengagement with push-button	
Electrical Connection	1m Cable, -TPC (Terminal with 1m cable)	
Direction of Rotation	Selected by switch	
Emergency stop direction	Selected by switch	
Position Indicator	Mechanical 5..20mm	Mechanical 5..32mm
Degree of Protection	IP54	
EMC	CE in accordance with 2004/108/CE	
Certification IEC/EN	Certified to IEC/EN 60730-1, IEC/EN 60730-2-14	
Ambient Temperature	0°C..+50°C	
Non-operation temperature	-40°C..+80°C	
Ambient Humidity	95% r.h., non-condensing	

The New Globe Valve Actuators

Based on the technology that has already proven itself in rotary actuators a million times over, Belimo is now bringing a new generation of globe valve actuators to the market to complete the comprehensive standardised actuator concept. To further enhance the field of application, the entire product range has been expanded to a power spectrum of 1000 to 4500N naturally to the usual Belimo quality standards. The compact design permits installation in stationary heating, ventilation and air conditioning systems where space is restricted. The new range is characterised by simple and intuitive handling, from mechanical connection to adjusting parameters.

Throttling Valves and Mixing Valves

Belimo globe valves have been designed for a long service life in closed-loop circuits carrying cold, warm or hot water. Internal thread or flanged end valves are available. The design of Belimo globe valves has been greatly improved in several important ways. Various optimised features have been incorporated with the aim of increasing their service life and reducing maintenance costs. The valves are always supplied as a turnkey functional solution, i.e. together with a suitable linear actuator. There are several alternative actuator types offering different actuating force ratings and emergency control functions.

Component parts of the globe valve: H2..X-S and H3..X-S

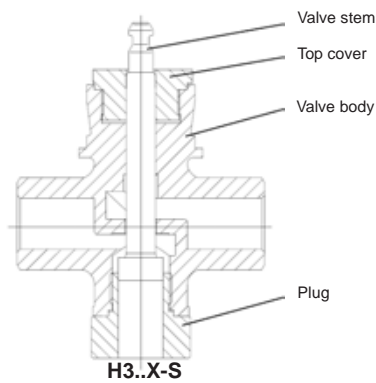
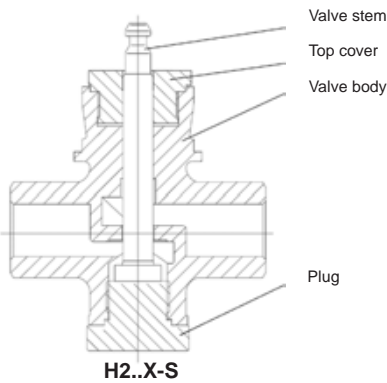

Component parts of the globe valve: H6..W-SP, H7..W-S (mixing) and H7..W-D (diverting)

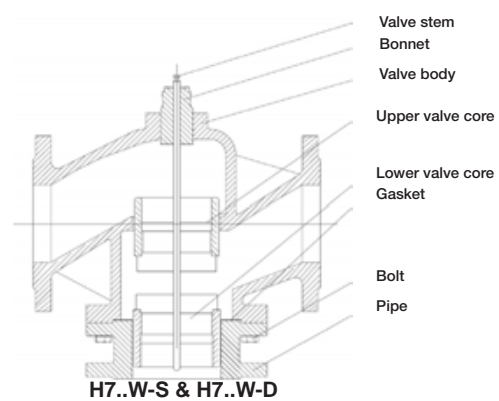
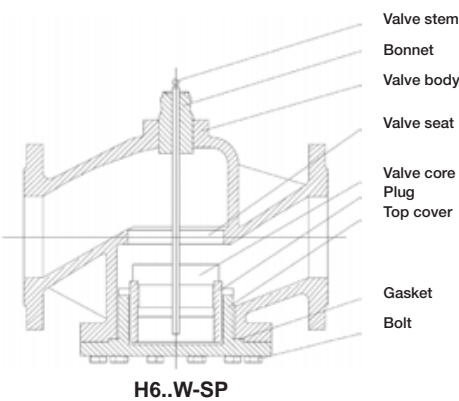

Balancing Core Structure

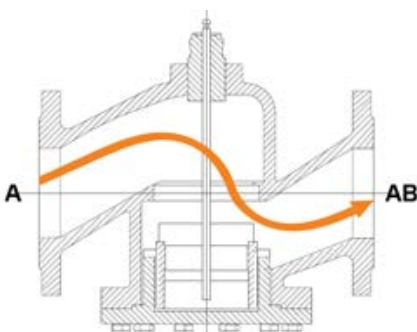

When valve is fully closed, differential pressure increases gradually. A small amount of water will leak into the seat through a tiny hole. This allows pressure within the seat to assimilate with the inlet pressure. Pressure load on seat will be minimised. Therefore, high close-off pressure can be achieved.

Inlet pressure = A, outlet pressure = AB

Standard Globe Valve Actuator

External adaptation push-button and LED status indicators

Slot for hand crank

Slot for auxiliary switch (optional)

Newly developed secondary drive

New, simplified connections for all Belimo valves

IP54 connecting terminals with 1m cable

Primary unit based on the tried and tested Belimo rotary actuators

Temporary and permanent gear disengagement

Newly designed bracket as part of the globe valve actuator

A hexagon socket screw key for all installation and adjustment work (attached to the actuator)

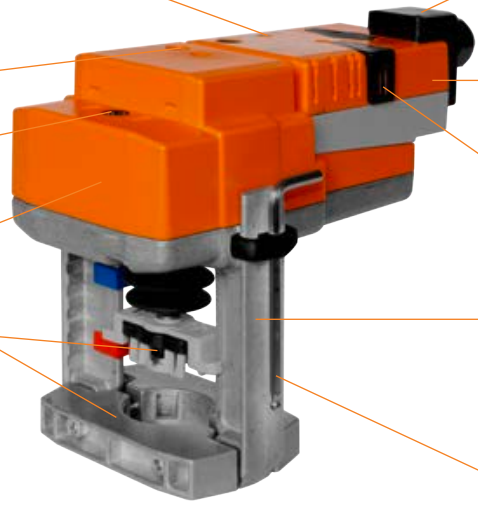

Globe valves, 2-way, with internal thread

- For open and closed cold and warm water systems
- For modulating water-side control of air handling units and heating systems
- VAV reheat

Type overview

Type	K _{vs} [m³/h]	DN [mm]	Stroke [mm]	S _v	ΔP _s [kPa]
H2015X-S	1.9	15	10	>50	800
H2020X-S	4.4	20	10	>50	800
H2025X-S	8	25	15	>50	600
H2032X-S	10	32	20	>50	550
H2040X-S	20	40	20	>50	450 / 700
H2050X-S	32	50	20	>50	300 / 500

ΔP_s will be variant depends on actuator selection.

Technical data

Functional data	Flow media	Cold and hot water, Refrigerant (R12, R22, R134a, R202), water with max. 50% volume of glycol, Hydrazine, Phosphate
	Temperature of medium	0°C ... +130°C
	Rated pressure P _s	2500kPa (PN25)
	Flow characteristic	Control path A – AB: equal percentage (to VDI/VDE 2173) n(gl) = 3, optimised in the opening range
	Rangeability S _v	See «Type overview»
	Leakage rate	Max. 0.02% of kvs value (DIN EN 1349 and DIN EN 60534-4)
	Pipe connection	Internal thread to ISO 7/1
	Stroke	See «Type overview»
	Valve closing point	Up (▲)
	Installation position	Upright to horizontal (in relation to the stem)
Materials	Maintenance	Maintenance-free
	Body	Stainless steel SS304
	Valve cone	Stainless steel SS304
	Valve stem	Stainless steel SS304
	Valve seat	Stainless steel SS304
Dimensions / Weights	Stem gland seal	EPDM O-Ring
	Dimensions and weights	See «Dimensions and weights»

Safety notes



- This globe valve has been designed for use in stationary heating, ventilation and air-conditioning systems and is not allowed to be used outside the specified field of application, especially in aircraft or in any other airborne means of transport.
- It may only be installed by suitably trained personnel. All applicable legal or institutional installation regulations must be complied with.
- The valve does not contain any parts that can be replaced or repaired by the user.
- The valve is not allowed to be disposed of as household refuse. All locally valid regulations and requirements must be observed.
- The recognised rules should be applied when determining the flow characteristic of final controlling elements.

Product features

Mode of operation	The globe valve is operated by an NV or SV series linear actuator. The linear actuators are controlled by a standard modulating or 3-point control system and move the cone of the valve, the throttling device, to the opening position dictated by the control signal.
Flow characteristic	An equal-percentage flow characteristic is produced by profiling the valve cone.
Manual operation	On the NV or SV linear actuator, the valve stem can be actuated manually using a hexagonal key.

Installation notes

Recommended mounting positions

The globe valve may be mounted either **vertically** or **horizontally**.
It is not permissible to mount the globe valve with the stem pointing downwards.

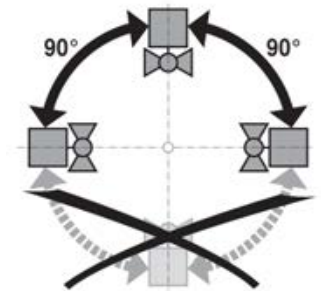

Water quality requirements

Maintenance

Direction of flow

- The water quality requirements specified in VDI 2035 must be adhered to.
- Globe valves are relatively sensitive control devices. In order to ensure a long service life, it is advisable to fit **strainers**.
- The globe valves and linear actuators are maintenance-free.
- Before any kind of service work is carried out on actuator sets of this type, it is essential to isolate the linear actuator from the power supply (by unplugging the power lead). Any pumps in the part of the piping system concerned must also be switched off and the appropriate isolating fittings closed (allow everything to cool down first if necessary and reduce the pressure in the system to atmospheric).
- The system must not be returned to service until the globe valve and the linear actuator have been properly reassembled in accordance with the instructions and the pipework has been refilled in the proper manner.
- The direction of flow, specified by an arrow on the housing, is to be complied with, since otherwise the globe valve can be damaged.

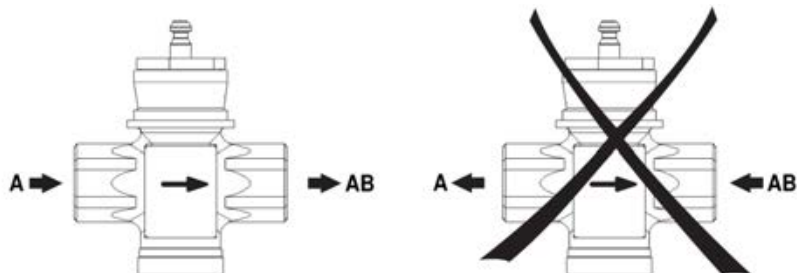

Dimensions and weights

Dimensional drawings

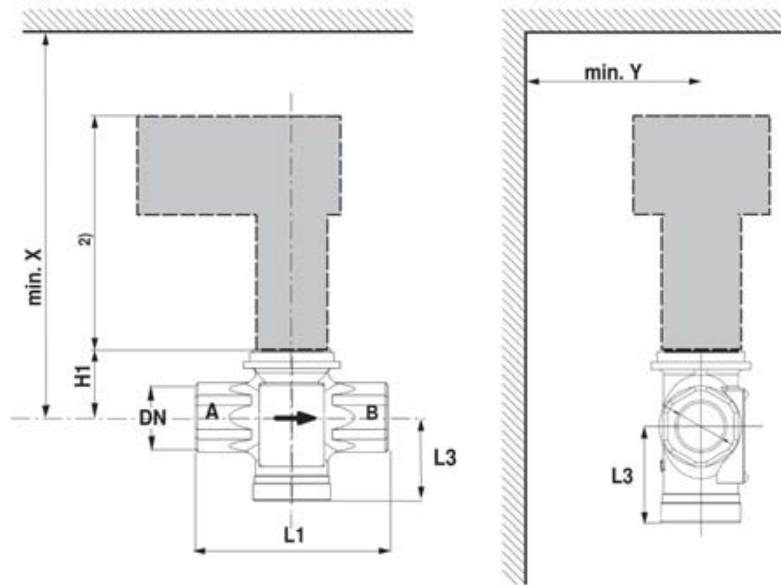

DN [mm]	L1 [mm]	H1 [mm]	L3 [mm]	X ¹⁾ [mm]	Y ¹⁾ [mm]	Weight [kg]
15	80	25.5	38	296	100	1
20	80	28	40	299	100	1.1
25	100	32	44	303	100	1.5
32	103	35	47	306	100	1.8
40	122	40.5	52	311	100	2.4
50	138	47	65	318	100	3.4

1) Minimum distance with respect to the valve centre.

2) The actuator dimensions can be found on the respective actuator data sheet.

Globe valves, 3-way, with internal thread

- For open and closed cold and hot water systems
- For modulating water-side control of air handling units and heating systems
- For converting and diverting application

Type overview

Type	K _{Vs} [m³/h]	DN [mm]	Stroke [mm]	S _v	ΔP _s [kPa]
H3015X-S	1.9	15	10	>50	800
H3020X-S	4.4	20	10	>50	800
H3025X-S	8	25	15	>50	600
H3032X-S	10	32	20	>50	550
H3040X-S	20	40	20	>50	450 / 700
H3050X-S	32	50	20	>50	300 / 500

ΔP_s will be variant depends on actuator selection.

Technical data

Functional data	Flow media	Cold and hot water, Refrigerant (R12, R22, R134a, R202), water with max. 50% volume of glycol, Hydrazine, Phosphate
	Temperature of medium	0°C ... +130°C
	Rated pressure P _s	2500kPa (PN25)
	Flow characteristic	Control path A-AB, B-AB: equal percentage (to VDI/VDE 2173) n(gl) = 3, optimised in the opening range
	Rangeability S _v	See «Type overview»
	Leakage rate	Max. 0.02% of kvs value on all path (DIN EN 1349 and DIN EN 60534-4)
	Pipe connection	Internal thread to ISO 7/1
	Stroke	See «Type overview»
	Valve closing point	Up (▲)
	Installation position	Upright to horizontal (in relation to the stem)
Materials	Maintenance	Maintenance-free
	Body	Stainless steel SS304
	Valve cone	Stainless steel SS304
	Valve stem	Stainless steel SS304
	Valve seat	Stainless steel SS304
Dimensions / Weights	Stem gland seal	Teflon
	Dimensions and weights	See «Dimensions and weights»

Safety notes



- This globe valve has been designed for use in stationary heating, ventilation and air-conditioning systems and is not allowed to be used outside the specified field of application, especially in aircraft or in any other airborne means of transport.
- It may only be installed by suitably trained personnel. All applicable legal or institutional installation regulations must be complied with.
- The valve does not contain any parts that can be replaced or repaired by the user.
- The valve is not allowed to be disposed of as household refuse. All locally valid regulations and requirements must be observed.
- The recognised rules should be applied when determining the flow characteristic of final controlling elements.

Product features

Mode of operation	The globe valve is operated by an NV or SV series linear actuator. The linear actuators are controlled by a standard modulating or 3-point control system and move the cone of the valve, the throttling device, to the opening position dictated by the control signal.
Flow characteristic	An equal-percentage flow characteristic is produced by profiling the valve cone. The bypass exhibits a linear characteristic curve.
Manual operation	On the NV or SV linear actuator, the valve stem can be actuated manually using a hexagonal key.

Installation notes

Recommended mounting positions

The globe valve may be mounted either **vertically** or **horizontally**.
It is not permissible to mount the globe valve with the stem pointing downwards.

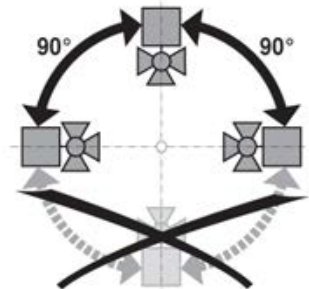

Water quality requirements

- The water quality requirements specified in VDI 2035 must be adhered to.
- Globe valves are relatively sensitive control devices. In order to ensure a long service life, it is advisable to fit **strainers**.

Maintenance

- The globe valves and linear actuators are maintenance-free.
- Before any kind of service work is carried out on actuator sets of this type, it is essential to isolate the linear actuator from the power supply (by unplugging the power lead). Any pumps in the part of the piping system concerned must also be switched off and the appropriate isolating fittings closed (allow everything to cool down first if necessary and reduce the pressure in the system to atmospheric).
- The system must not be returned to service until the globe valve and the linear actuator have been properly reassembled in accordance with the instructions and the pipework has been refilled in the proper manner.

Direction of flow

- The direction of flow, specified by an arrow on the housing, is to be complied with, since otherwise the globe valve can be damaged.

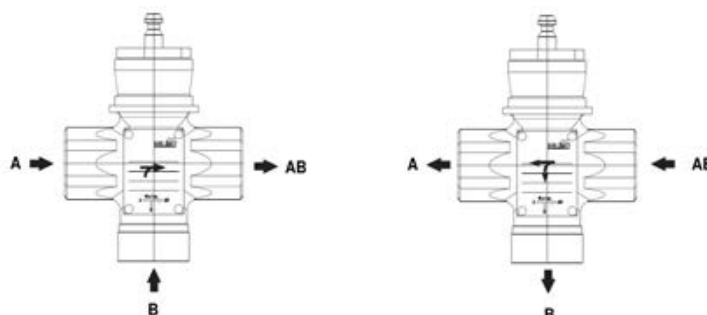

Dimensions and weights

Dimensional drawings

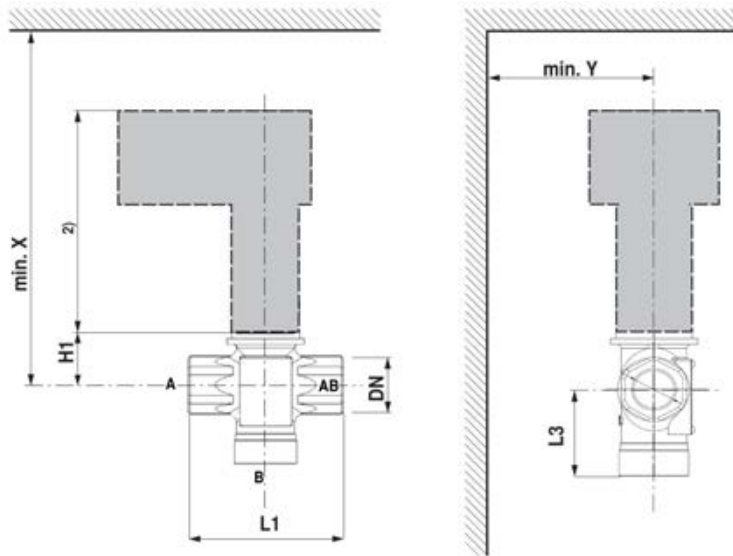

DN [mm]	L1 [mm]	H1 [mm]	L3 [mm]	X ¹⁾ [mm]	Y ¹⁾ [mm]	Weight [kg]
15	80	25.5	49	296	100	0.8
20	80	28	51	299	100	1.1
25	100	32	55	303	100	1.6
32	103	35	62	306	100	1.8
40	122	40.5	71	311	100	2.3
50	138	47	85	318	100	3.3

1) Minimum distance with respect to the valve centre.

2) The actuator dimensions can be found on the respective actuator data sheet.

Globe valves, 2-way, with flange PN16

- For closed cold and hot water systems
- For modulating water-side control of air handling units and heating systems



Type overview

Type	K _{vs} [m³/h]	DN [mm]	Stroke [mm]	S _v	ΔP _s [kPa]
H6065W-SP	50	65	20	>50	1600
H6080W-SP	80	80	30	>50	1600
H6100W-SP	125	100	40	>50	1600
H6125W-SP	200	125	40	>50	1600
H6150W-SP	300	150	40	>50	1600
H6200W-SP	520	200	40	>50	1600
H6250W-SP	750	250	40	>50	1600

Technical data

Functional data	Flow media	Cold and hot water, Refrigerant (R12, R22, R134a, R202), water with max. 50% volume of glycol, Hydrazine, Phosphate
	Temperature of medium	0°C ... +150°C
	Rated pressure P _s	1600kPa (PN16)
	Flow characteristic	Control path A – AB: equal percentage (to VDI/VDE 2173) n(gl) = 3, optimised in the opening range
	Rangeability S _v	See «Type overview»
	Leakage rate	Max. 0.02% of kvs value (DIN EN 1349 and DIN EN 60534-4)
	Pipe connection	Flange to ISO 7005-2 (PN16)
	Stroke	See «Type overview»
	Valve closing point	Up (▲)
	Installation position	Upright to horizontal (in relation to the stem)
	Maintenance	Maintenance-free
	Materials	Body
Valve cone		Stainless steel SS304
Valve stem		Stainless steel SS304
Valve seat		Stainless steel SS304
Stem gland seal		Teflon
Dimensions / Weights	Dimensions and weights	See «Dimensions and weights»

Safety notes



- This globe valve has been designed for use in stationary heating, ventilation and air-conditioning systems and is not allowed to be used outside the specified field of application, especially in aircraft or in any other airborne means of transport.
- It may only be installed by suitably trained personnel. All applicable legal or institutional installation regulations must be complied with.
- The valve does not contain any parts that can be replaced or repaired by the user.
- The valve is not allowed to be disposed of as household refuse. All locally valid regulations and requirements must be observed.
- The recognised rules should be applied when determining the flow characteristic of final controlling elements.

Product features

Mode of operation	The globe valve is operated by an SV, EV or RV series linear actuator. The linear actuators are controlled by a standard modulating or 3-point control system and move the cone of the valve, the throttling device, to the opening position dictated by the control signal.
Flow characteristic	An equal-percentage flow characteristic is produced by profiling the valve cone.
Manual operation	On the SV, EV or RV linear actuator, the valve stem can be actuated manually using a hexagonal key.

Installation notes

Recommended mounting positions

The globe valve may be mounted either **vertically** or **horizontally**. It is not permissible to mount the globe valve with the stem pointing downwards.

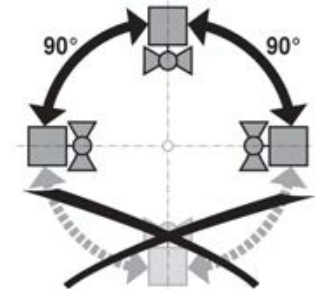

Water quality requirements

- The water quality requirements specified in VDI 2035 must be adhered to.
- Globe valves are relatively sensitive control devices. In order to ensure a long service life, it is advisable to fit **strainers**.

Maintenance

- The globe valves and linear actuators are maintenance-free.
- Before any kind of service work is carried out on actuator sets of this type, it is essential to isolate the linear actuator from the power supply (by unplugging the power lead). Any pumps in the part of the piping system concerned must also be switched off and the appropriate isolating fittings closed (allow everything to cool down first if necessary and reduce the pressure in the system to atmospheric).
- The system must not be returned to service until the globe valve and the linear actuator have been properly reassembled in accordance with the instructions and the pipework has been refilled in the proper manner.

Direction of flow

- The direction of flow, specified by an arrow on the housing, is to be complied with, since otherwise the globe valve can be damaged.

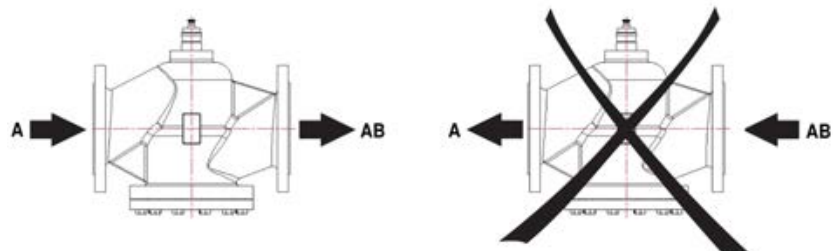

Dimensions and weights

Dimensional drawings

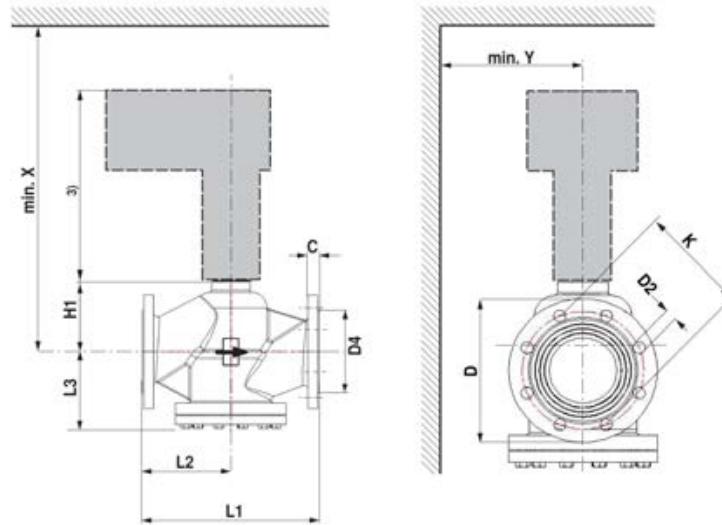

DN [mm]	B [mm]	D [mm]	D2 [mm]	D4 [mm]	K [mm]	L1 [mm]	L2 [mm]	L3 [mm]	H1 [mm]	X ²⁾ [mm]	Y ²⁾ [mm]	Weight [kg]
65	22	185	4-18	118	145	290	145	115	105	376	665	18.5
80	22	200	8-18	132	160	310	155	130	118	502	665	25
100	23	220	8-18	156	180	350	175	150	135	519	665	35.6
125	24	250	8-18	184	210	400	200	175	160	544	665	50.6
150	25	285	8-22	211	240	480	240	200	169	553	665	71.5
200	26	340	12-22	266	295	500	250	236	263	647	665	112.7
250	31	405	12-26	319	355	600	300	295	315	699	665	202

2) Minimum distance with respect to the valve centre.

3) The actuator dimensions can be found on the respective actuator data sheet.

Globe valves, 3-way, with flange PN16

- For closed cold and hot water systems
- For modulating water-side control of air handling units and heating systems

Type overview

Type	K_{vs} [m ³ /h]	DN [mm]	Stroke [mm]	S_v	ΔP_s [kPa]
H7065W-S*	50	65	20	>50	450
H7080W-S	80	80	30	>50	270 / 350
H7100W-S	125	100	40	>50	200 / 300
H7125W-S	200	125	40	>50	150 / 200
H7150W-S	300	150	40	>50	100 / 150
H7200W-S	520	200	40	>50	130
H7250W-S	750	250	40	>50	80

ΔP_s will be variant depends on actuator selection.

*H7065W-S is available for diverting application.

Technical data

Functional data	Flow media	Cold and hot water, Refrigerant (R12, R22, R134a, R202), water with max. 50% volume of glycol, Hydrazine, Phosphate
	Temperature of medium	0°C ... +150°C
	Rated pressure P_s	1600kPa (PN16)
	Flow characteristic	Control path A-AB, B-AB: equal percentage (to VDI/VDE 2173) $n(gl) = 3$, optimised in the opening range
	Rangeability S_v	See «Type overview»
	Leakage rate	Max. 0.02% of kvs value on all path (DIN EN 1349 and DIN EN 60534-4)
	Pipe connection	Flange to ISO 7005-2 (PN16)
	Stroke	See «Type overview»
	Valve closing point	Up (▲)
	Installation position	Upright to horizontal (in relation to the stem)
Materials	Maintenance	Maintenance-free
	Body	Ductile iron GGG40
	Valve cone	Stainless steel SS304
	Valve stem	Stainless steel SS304
	Valve seat	Stainless steel SS304
Dimensions / Weights	Stem gland seal	Teflon
	Dimensions and weights	See «Dimensions and weights»

Safety notes



- This globe valve has been designed for use in stationary heating, ventilation and air-conditioning systems and is not allowed to be used outside the specified field of application, especially in aircraft or in any other airborne means of transport.
- It may only be installed by suitably trained personnel. All applicable legal or institutional installation regulations must be complied with.
- The valve does not contain any parts that can be replaced or repaired by the user.
- The valve is not allowed to be disposed of as household refuse. All locally valid regulations and requirements must be observed.
- The recognised rules should be applied when determining the flow characteristic of final controlling elements.

Product features

Mode of operation	The globe valve is operated by an SV, EV or RV series linear actuator. The linear actuators are controlled by a standard modulating or 3-point control system and move the cone of the valve, the throttling device, to the opening position dictated by the control signal.
Flow characteristic	An equal-percentage flow characteristic is produced by profiling the valve cone. The bypass exhibits a linear characteristic curve.
Manual operation	On the SV, EV or RV linear actuator, the valve stem can be actuated manually using a hexagonal key.

Installation notes

Recommended mounting positions

The globe valve may be mounted either **vertically** or **horizontally**. It is not permissible to mount the globe valve with the stem pointing downwards.

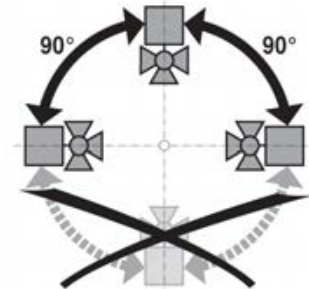

Water quality requirements

- The water quality requirements specified in VDI 2035 must be adhered to.
- Globe valves are relatively sensitive control devices. In order to ensure a long service life, it is advisable to fit **strainers**.

Maintenance

- The globe valves and linear actuators are maintenance-free.
- Before any kind of service work is carried out on actuator sets of this type, it is essential to isolate the linear actuator from the power supply (by unplugging the power lead). Any pumps in the part of the piping system concerned must also be switched off and the appropriate isolating fittings closed (allow everything to cool down first if necessary and reduce the pressure in the system to atmospheric).
- The system must not be returned to service until the globe valve and the linear actuator have been properly reassembled in accordance with the instructions and the pipework has been refilled in the proper manner.

Direction of flow

- The direction of flow, specified by an arrow on the housing, is to be complied with, since otherwise the globe valve can be damaged.

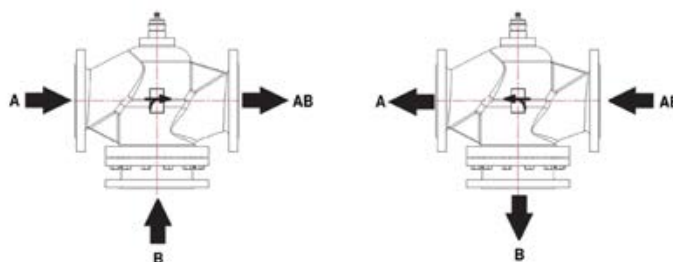

H7065W-S only

Dimensions and weights

Dimensional drawings

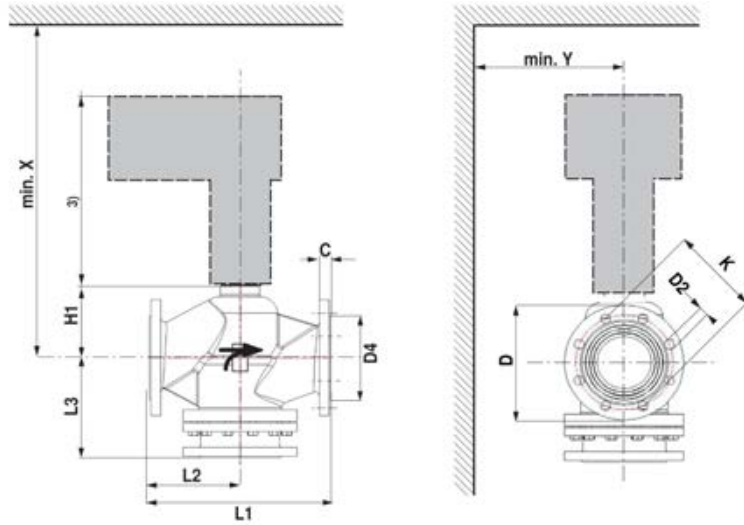

DN [mm]	C [mm]	D [mm]	D2 [mm]	D4 [mm]	K [mm]	L1 [mm]	L2 [mm]	L3 [mm]	H1 [mm]	X [mm]	Y [mm]	Weight [kg]
65	22	185	4-18	118	145	290	145	115	105	376	150	22.5
80	22	200	8-18	132	160	310	155	182	118	502	150	28.8
100	23	220	8-18	156	180	350	175	200	135	519	150	40.6
125	24	250	8-18	184	210	400	200	240	160	544	150	55.4
150	25	285	8-22	211	240	480	240	268	169	553	150	76.3
200	26	340	12-22	266	295	500	250	320	263	647	150	125.6
250	31	405	12-26	319	355	600	300	400	315	699	150	230

3) The actuator dimensions can be found on the respective actuator data sheet.

Globe valves, 3-way, with flange PN16

- For closed cold and hot water systems
- For modulating water-side control of air handling units and heating systems
- For diverting application only

Type overview

Type	K _{vs} [m³/h]	DN [mm]	Stroke [mm]	S _v	ΔP _s [kPa]
H7080W-D	80	80	30	>50	270 / 350
H7100W-D	125	100	40	>50	200 / 300
H7125W-D	200	125	40	>50	150 / 200
H7150W-D	300	150	40	>50	100 / 150

ΔP_s will be variant depends on actuator selection.

Technical data
Functional data

Flow media	Cold and hot water, Refrigerant (R12, R22, R134a, R202), water with max. 50% volume of glycol, Hydrazine, Phosphate
Temperature of medium	0°C ... +150°C
Rated pressure P _s	1600kPa (PN16)
Flow characteristic	Control path AB-A, AB-B: equal percentage (to VDI/VDE 2173) n(gl) = 3, optimized in the opening range
Rangeability S _v	See «Type overview»
Leakage rate	Max. 0.02% of kvs value on all path (DIN EN 1349 and DIN EN 60534-4)
Pipe connection	Flange to ISO 7005-2 (PN16)
Stroke	See «Type overview»
Valve closing point	Up (▲)
Installation position	Upright to horizontal (in relation to the stem)
Maintenance	Maintenance-free

Materials

Body	Ductile iron GGG40
Valve cone	Stainless steel SS304
Valve stem	Stainless steel SS304
Valve seat	Stainless steel SS304
Stem gland seal	Teflon

Dimensions / Weights

Dimensions and weights	See «Dimensions and weights»
------------------------	------------------------------

Safety notes

- This globe valve has been designed for use in stationary heating, ventilation and air-conditioning systems and is not allowed to be used outside the specified field of application, especially in aircraft or in any other airborne means of transport.
- It may only be installed by suitably trained personnel. All applicable legal or institutional installation regulations must be complied with.
- The valve does not contain any parts that can be replaced or repaired by the user.
- The valve is not allowed to be disposed of as household refuse. All locally valid regulations and requirements must be observed.
- The recognised rules should be applied when determining the flow characteristic of final controlling elements.

Product features

Mode of operation	The globe valve is operated by an EV or RV series linear actuator. The linear actuators are controlled by a standard modulating or 3-point control system and move the cone of the valve, the throttling device, to the opening position dictated by the control signal.
Flow characteristic	An equal-percentage flow characteristic is produced by profiling the valve cone. The bypass exhibits a linear characteristic curve.
Manual operation	On the EV or RV linear actuator, the valve stem can be actuated manually using a hexagonal key.

Installation notes

Recommended mounting positions

The globe valve may be mounted either **vertically** or **horizontally**. It is not permissible to mount the globe valve with the stem pointing downwards.

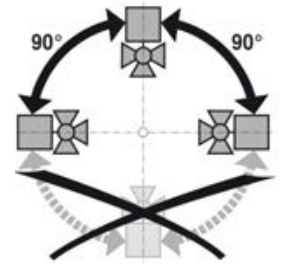

Water quality requirements

- The water quality requirements specified in VDI 2035 must be adhered to.
- Globe valves are relatively sensitive control devices. In order to ensure a long service life, it is advisable to fit **strainers**.

Maintenance

- The globe valves and linear actuators are maintenance-free.
- Before any kind of service work is carried out on actuator sets of this type, it is essential to isolate the linear actuator from the power supply (by unplugging the power lead). Any pumps in the part of the piping system concerned must also be switched off and the appropriate isolating fittings closed (allow everything to cool down first if necessary and reduce the pressure in the system to atmospheric).
- The system must not be returned to service until the globe valve and the linear actuator have been properly reassembled in accordance with the instructions and the pipework has been refilled in the proper manner.

Direction of flow

- The direction of flow, specified by an arrow on the housing, is to be complied with, since otherwise the globe valve can be damaged.

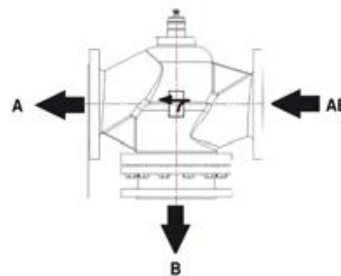

Dimensions and weights

Dimensional drawings

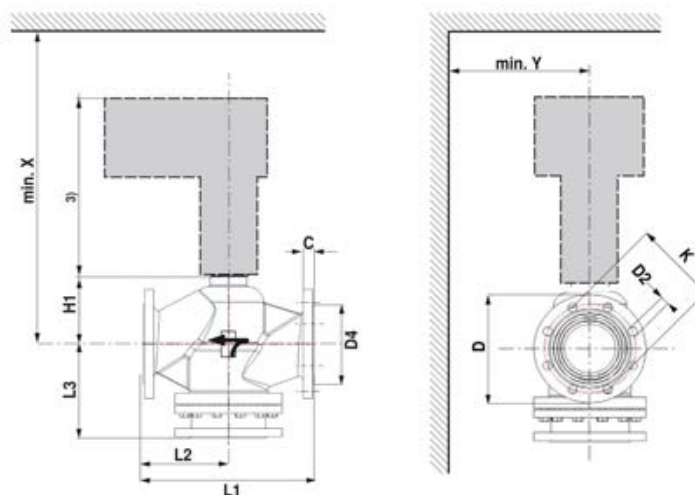

DN	C	D	D2	D4	K	L1	L2	L3	H1	X	Y	Weight
[mm]	[mm]	[mm]	[mm]	[mm]	[mm]	[mm]	[mm]	[mm]	[mm]	[mm]	[mm]	[kg]
80	22	200	8-18	132	160	310	155	182	118	502	150	28.8
100	23	220	8-18	156	180	350	175	200	135	519	150	40.6
125	24	250	8-18	184	210	400	200	240	160	544	150	55.4
150	25	285	8-22	211	240	480	240	268	169	553	150	76.3

3) The actuator dimensions can be found on the respective actuator data sheet.

Dimensions

H2..X-S Globe valve 2-way series, PN25

Model Type	DN		Dimension[mm]					Weight (kg)
	In	mm	L1	L3	H1	H2	H	
H2015X-S	1/2"	15	80	38	25.5	66	296	1.0
H2020X-S	3/4"	20	80	40	28	68.5	299	1.1
H2025X-S	1"	25	100	44	32	72.5	303	1.5
H2032X-S	1-1/4"	30	103	47	35	75.5	306	1.8
H2040X-S	1-1/2"	40	122	52	40.5	81	311	2.4
H2050X-S	2"	50	138	65	47	87.5	318	3.4

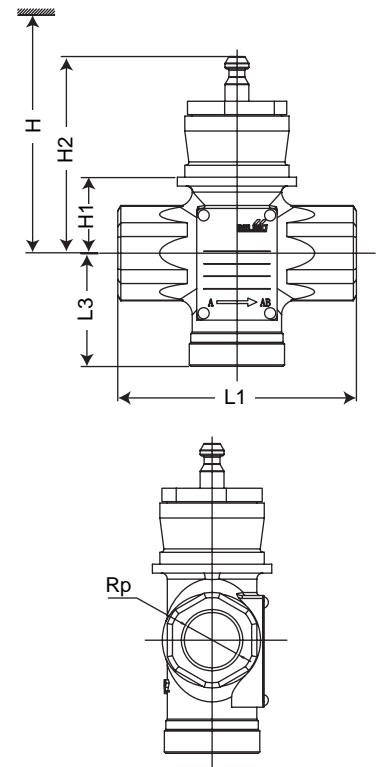

H3..X-S Globe valve 3-way series, PN25

Model Type	DN		Dimension[mm]					Weight (kg)
	In	mm	L1	L3'	H1	H2	H	
H3015X-S	1/2"	15	80	49	25.5	66	296	0.8
H3020X-S	3/4"	20	80	51	28	68.5	299	1.1
H3025X-S	1"	25	100	55	32	72.5	303	1.6
H3032X-S	1-1/4"	30	103	62	35	75.5	306	1.8
H3040X-S	1-1/2"	40	122	71	40.5	81	311	2.3
H3050X-S	2"	50	138	85	47	87.5	318	3.3

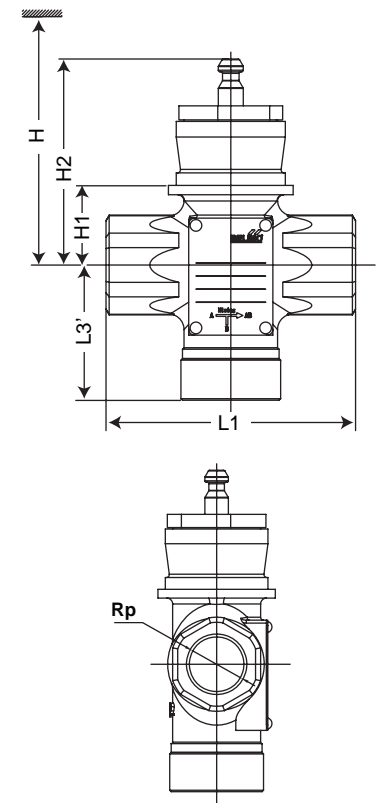

Dimensions

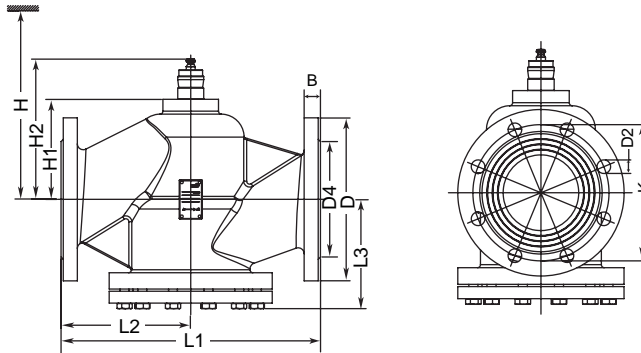

H6..W-SP Globe valve 2-way series, PN16

Model Type	DN	Dimension[mm]											Weight (kg)
	mm	B	D	D2	D4	K	L1	L2	L3	H1	H2	H	
H6065W-SP	65	22	185	4-18	118	145	290	145	115	105	145.5	376	18.5
H6080W-SP	80	22	200	8-18	132	160	310	155	130	118	172.5	502	25.0
H6100W-SP	100	23	220	8-18	156	180	350	175	150	135	189.5	519	35.6
H6125W-SP	125	24	250	8-18	184	210	400	200	175	160	214.5	544	50.6
H6150W-SP	150	25	285	8-22	211	240	480	240	200	169	223.5	553	71.5
H6200W-SP	200	26	340	12-22	266	295	500	250	236	263	317.5	647	112.7
H6250W-SP	250	31	405	12-26	319	355	600	300	295	315	369.5	699	202.0

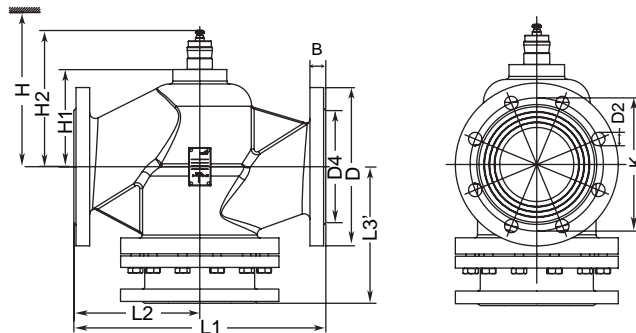

H7..W-S Globe valve 3-way series and H7..W-D (diverting), PN16

Model Type	DN	Dimension[mm]											Weight (kg)
	mm	B	D	D2	D4	K	L1	L2	L3	H1	H2	H	
H7065W-S	65	22	185	4-18	118	145	290	145	155	105	145.5	376	22.5
H7080W-S	80	22	200	8-18	132	160	310	155	182	118	172.5	502	28.8
H7080W-D	80	22	200	8-18	132	160	310	155	182	118	172.5	502	28.8
H7100W-S	100	23	220	8-18	156	180	350	175	200	135	189.5	519	40.6
H7100W-D	100	23	220	8-18	156	180	350	175	200	135	189.5	519	40.6
H7125W-S	125	24	250	8-18	184	210	400	200	240	160	214.5	544	55.4
H7125W-D	125	24	250	8-18	184	210	400	200	240	160	214.5	544	55.4
H7150W-S	150	25	285	8-22	211	240	480	240	268	169	223.5	553	76.3
H7150W-D	150	25	285	8-22	211	240	480	240	268	169	223.5	553	76.3
H7200W-S	200	26	340	12-22	266	295	500	250	320	263	317.5	647	125.6
H7250W-S	250	31	405	12-26	319	355	600	300	400	315	369.5	699	230.0

Globe valve actuator for 2-way and 3-way globe valves

- Actuating force 1000N
- Nominal voltage AC/DC 24V
- Control: Open-close, 3-point
- Nominal stroke 20mm



Technical data

Electrical data	Nominal voltage	AC/DC 24V
	Nominal voltage frequency	50/60Hz
	Nominal voltage range	AC 19.2...28.8V / DC 21.6...28.8V
	Power consumption in operation	1.5W
	Power consumption in rest position	0.5W
	Power consumption for wire sizing	3VA
	Connection supply / control	Terminals 4mm ² and cable 1m, 3 x 0.75mm ²
Functional data	Parallel operation	Yes
	Actuating force	1000N
	Manual override	Gear disengagement with push-button, can be locked
	Nominal stroke	20mm
	Actuating time	150s/20mm
	Sound power level motor max.	45dB(A)
	Position indication	Mechanical 5...20mm stroke
Safety	Protection class IEC/EN	III Safety extra-low voltage
	Degree of protection IEC/EN	IP54
	EMC	CE in accordance with 2004/108/EC
	Certification IEC/EN	Certified to: IEC/EN 60730-1 and IEC/EN 60730-2-14
	Mode of operation	Type 1
	Rated impulse voltage supply / control	0.8kV
	Control pollution degree	3
Weight	Ambient temperature	0°C...50°C
	Non-operating temperature	-40°C...80°C
	Ambient humidity	95% r.h., non-condensing
	Maintenance	Maintenance-free
	Weight approx.	1.32kg

Safety notes



- This actuator has been designed for application in stationary heating, ventilation and air-conditioning systems and is not allowed to be used outside the specified field of application, especially in aircraft or in any other airborne means of transport.
- Only authorised specialists may carry out installation. All applicable legal or institutional installation regulations must be complied with during installation.
- The switch for changing the direction of motion/the closing point may be adjusted only by authorised personnel. The direction of stroke is critical, particularly in connection with frost protection circuits.
- The device may only be opened at the manufacturer's site. It does not contain any parts that can be replaced or repaired by the user.
- The device contains electrical and electronic components and is not allowed to be disposed of as household refuse. All locally valid regulations and requirements must be observed.

Product features

Direct mounting	Simple direct mounting on the globe valve by means of form-fit hollow clamping jaws. The actuator can be rotated through 360° on the valve neck.
Manual override	Manual control with push-button possible - temporary, permanently. The gear is disengaged and the actuator decoupled for as long as the button is pressed / latched. The stroke can be adjusted by using a hexagon socket screw key (4mm), which is inserted into the top of the actuator. The stroke spindle extends when the key is rotated clockwise.
High functional reliability	The actuator is overload protected, requires no limit switches and automatically stops when the end stop is reached.
Combination valve/actuator	Refer to the valve documentation for suitable valves, their permitted medium temperatures and closing pressures.
Position indication	The stroke is indicated mechanically on the bracket with tabs. The stroke range adjusts itself automatically during operation.
Home position	Setting ex-works: Actuator spindle is retracted. When valve-actuator combinations are shipped, the direction of motion is set in accordance with the closing point of the valve.
Direction of stroke switch	When actuated, the direction of stroke switch changes the running direction in normal operation.

Accessories

Electrical accessories

Description

Type

Auxiliary switch

S2A-H

Electrical installation



- Notes
- Connection via safety isolating transformer.
 - Parallel connection of other actuators possible.
 - Direction of stroke switch factory setting: Actuator spindle retracted.

Wiring diagrams

AC/DC 24V, open-close (one-wire)

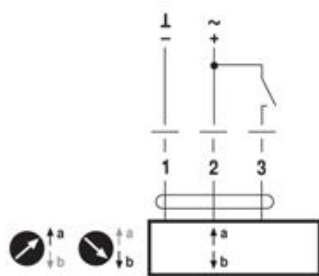

Cable colours:
1 = black
2 = red
3 = white

AC/DC 24V, 3-point

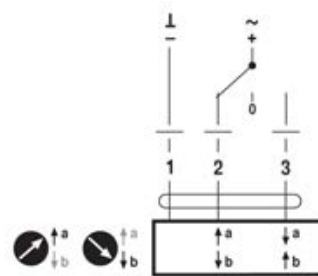

Cable colours:
1 = black
2 = red
3 = white

Indicators and operating controls

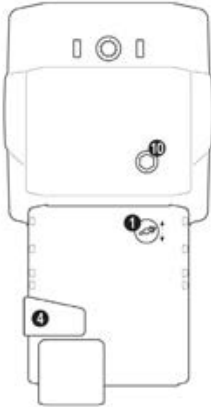

(1) Direction of stroke switch

Switching: Direction of stroke changes

(4) Gear disengagement button

Press button: Gear disengages, motor stops, manual override possible

Release button: Gear engages, standard mode

(10) Manual override

Clockwise: Actuator spindle extends

Counterclockwise: Actuator spindle retracts

Dimensions [mm]

Dimensional drawings

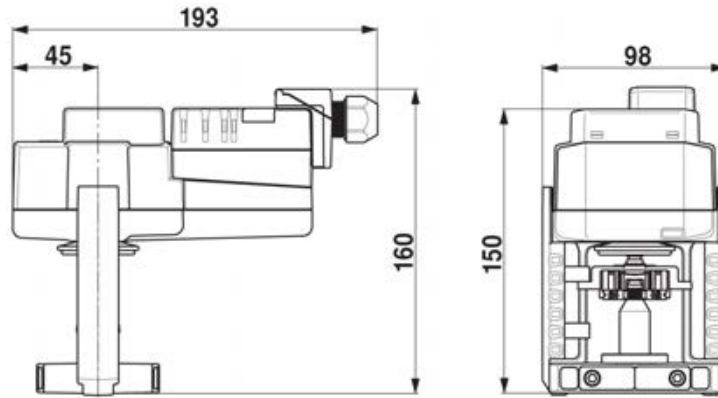

Globe valve actuator for 2-way and 3-way globe valves

- Actuating force 1000N
- Nominal voltage AC 230V
- Control: Open-close, 3-point
- Nominal stroke 20mm

Technical data

Electrical data	Nominal voltage	AC 230V
	Nominal voltage frequency	50/60Hz
	Nominal voltage range	AC 198...264V
	Power consumption in operation	2W
	Power consumption in rest position	1W
	Power consumption for wire sizing	4.5VA
	Connection supply / control	Terminals 4mm ² and cable 1m, 3 x 0.75mm ²
Functional data	Parallel operation	Yes
	Actuating force	1000N
	Manual override	Gear disengagement with push-button, can be locked
	Nominal stroke	20mm
	Actuating time	150s/20mm
	Sound power level motor max.	45dB(A)
	Position indication	Mechanical 5...20mm stroke
Safety	Protection class IEC/EN	II Protective insulated
	Degree of protection IEC/EN	IP54
	EMC	CE in accordance with 2004/108/EC
	Certification IEC/EN	Certified to: IEC/EN 60730-1 and IEC/EN 60730-2-14
	Mode of operation	Type 1
	Rated impulse voltage supply / control	4kV
	Control pollution degree	3
Weight	Ambient temperature	0°C...50°C
	Non-operating temperature	-40°C...80°C
	Ambient humidity	95% r.h., non-condensing
	Maintenance	Maintenance-free
Weight	Weight approx.	1.32kg

Safety notes

- This actuator has been designed for application in stationary heating, ventilation and air-conditioning systems and is not allowed to be used outside the specified field of application, especially in aircraft or in any other airborne means of transport.
- Only authorised specialists may carry out installation. All applicable legal or institutional installation regulations must be complied with during installation.
- The switch for changing the direction of motion/the closing point may be adjusted only by authorised personnel. The direction of stroke is critical, particularly in connection with frost protection circuits.
- The device may only be opened at the manufacturer's site. It does not contain any parts that can be replaced or repaired by the user.
- The device contains electrical and electronic components and is not allowed to be disposed of as household refuse. All locally valid regulations and requirements must be observed.

Product features

Direct mounting	Simple direct mounting on the globe valve by means of form-fit hollow clamping jaws. The actuator can be rotated through 360° on the valve neck.
Manual override	Manual control with push-button possible - temporary, permanently. The gear is disengaged and the actuator decoupled for as long as the button is pressed / latched. The stroke can be adjusted by using a hexagon socket screw key (4mm), which is inserted into the top of the actuator. The stroke spindle extends when the key is rotated clockwise.
High functional reliability	The actuator is overload protected, requires no limit switches and automatically stops when the end stop is reached.
Combination valve/actuator	Refer to the valve documentation for suitable valves, their permitted medium temperatures and closing pressures.
Position indication	The stroke is indicated mechanically on the bracket with tabs. The stroke range adjusts itself automatically during operation.
Home position	Setting ex-works: Actuator spindle is retracted. When valve-actuator combinations are shipped, the direction of motion is set in accordance with the closing point of the valve.
Direction of stroke switch	When actuated, the direction of stroke switch changes the running direction in normal operation.

Accessories

Electrical accessories

Description

Type

Auxiliary switch

S2A-H

Electrical installation



- Notes
- Parallel connection of other actuators possible.
 - Direction of stroke switch factory setting: Actuator spindle retracted.

Wiring diagrams

AC 230V, open-close (one-wire)

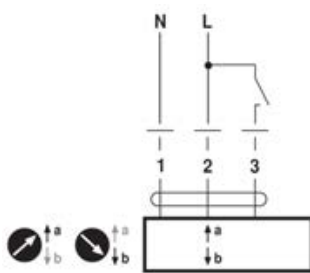

Cable colours:
1 = blue
2 = brown
3 = white

AC 230V, 3-point

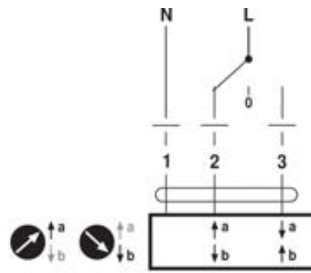

Cable colours:
1 = blue
2 = brown
3 = white

Indicators and operating controls

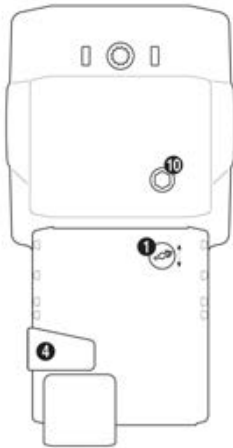

(1) Direction of stroke switch

Switching: Direction of stroke changes

(4) Gear disengagement button

Press button: Gear disengages, motor stops, manual override possible

Release button: Gear engages, standard mode

(10) Manual override

Clockwise: Actuator spindle extends

Counterclockwise: Actuator spindle retracts

Dimensions [mm]

Dimensional drawings

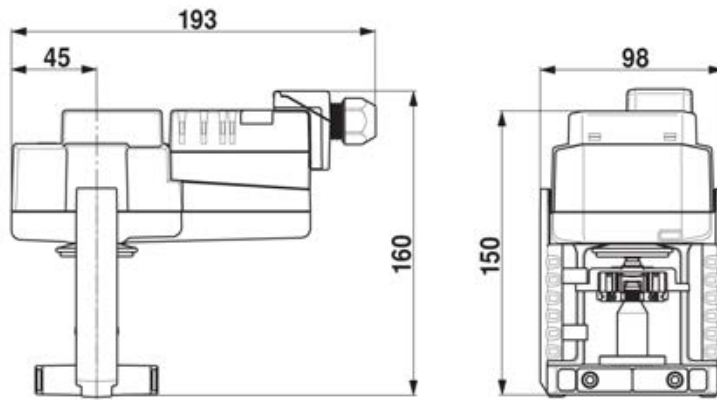

Modulating globe valve actuator for 2-way and 3-way globe valves

- Actuating force 1000N
- Nominal voltage AC/DC 24V
- Control: modulating DC (0)0.5V...10V
- Nominal stroke 20mm



Technical data

Electrical data	Nominal voltage	AC/DC 24V
	Nominal voltage frequency	50/60Hz
	Nominal voltage range	AC 19.2...28.8V / DC 21.6...28.8V
	Power consumption in operation	1.5W
	Power consumption in rest position	0.5W
	Power consumption for wire sizing	3VA
	Connection supply / control	Terminals 4mm ² and cable 1m, 4 x 0.75mm ²
	Parallel operation	Yes
Functional data	Actuating force	1000N
	Positioning signal Y	DC 0...10V
	Positioning signal Y note	Input impedance 100kΩ
	Operating range Y	DC 0.5...10V
	Position feedback U	DC 0.5...10V
	Position feedback U note	max. 0.5mA
	Position accuracy	5% absolute
	Manual override	Gear disengagement with push-button, can be locked
	Nominal stroke	20mm
	Actuating time	150s/20mm
	Sound power level motor max.	45dB(A)
	Position indication	Mechanical 5...20mm stroke
Safety	Protection class IEC/EN	III Safety extra-low voltage
	Degree of protection IEC/EN	IP54
	EMC	CE in accordance with 2004/108/EC
	Certification IEC/EN	Certified to: IEC/EN 60730-1 and IEC/EN 60730-2-14
Weight	Mode of operation	Type 1
	Rated impulse voltage supply / control	0.8kV
	Control pollution degree	3
	Ambient temperature	0°C...50°C
	Non-operating temperature	-40°C...80°C
	Ambient humidity	95% r.h., non-condensing
	Maintenance	Maintenance-free
	Weight approx.	1.34kg

Safety notes



- This actuator has been designed for application in stationary heating, ventilation and air-conditioning systems and is not allowed to be used outside the specified field of application, especially in aircraft or in any other airborne means of transport.
- Only authorised specialists may carry out installation. All applicable legal or institutional installation regulations must be complied with during installation.
- The switch for changing the direction of motion/the closing point may be adjusted only by authorised personnel. The direction of stroke is critical, particularly in connection with frost protection circuits.
- The device may only be opened at the manufacturer's site. It does not contain any parts that can be replaced or repaired by the user.

Safety notes

- The device contains electrical and electronic components and is not allowed to be disposed of as household refuse. All locally valid regulations and requirements must be observed.

Product features

Principle of operation

The actuator is connected with a standard modulating signal of DC 0...10V and travels to the position defined by the positioning signal. The measuring voltage U serves for the electrical display of the actuator position 0...100% and as slave control signal for other actuators.

Direct mounting

Simple direct mounting on the globe valve by means of form-fit hollow clamping jaws. The actuator can be rotated through 360° on the valve neck.

Manual override

Manual override with push-button possible - temporary, permanently. The gear is disengaged and the actuator decoupled for as long as the button is pressed / latched. The stroke can be adjusted by using a hexagon socket screw key (4mm), which is inserted into the top of the actuator. The stroke spindle extends when the key is rotated clockwise.

High functional reliability

The actuator is overload protected, requires no limit switches and automatically stops when the end stop is reached.

Combination valve/actuator

Refer to the valve documentation for suitable valves, their permitted medium temperatures and closing pressures.

Position indication

The stroke is indicated mechanically on the bracket with tabs. The stroke range adjusts itself automatically during operation.

Home position

Setting ex-works: Actuator spindle is retracted.
When valve-actuator combinations are shipped, the direction of motion is set in accordance with the closing point of the valve.

Direction of stroke switch

When actuated, the direction of stroke switch changes the running direction in normal operation.

Adaption of stroke range

The first time the supply voltage is switched on, i.e. at the time of commissioning, the actuator carries out a stroke adaption, which is when the operating range and position feedback adjust themselves to the mechanical stroke.

Manual triggering of the adaption can be carried out by pressing the "Adaption" button. The actuator then moves into the position defined by the positioning signal.

Accessories

Electrical accessories

Description	Type
Auxiliary switch add-on, 2 x SPDT	S2A-H

Electrical installation



- Notes
- Connection via safety isolating transformer.
 - Parallel connection of other actuators possible
 - Direction of stroke switch factory setting: Actuator spindle retracted.

Wiring diagrams

AC/DC 24V, modulating

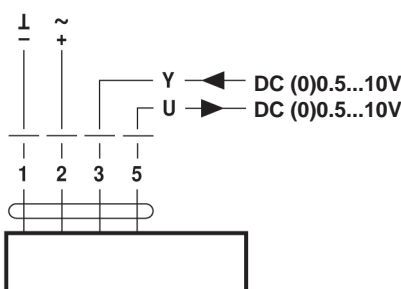

- Cable colours:
- 1 = black
 - 2 = red
 - 3 = white
 - 5 = orange

Indicators and operating controls

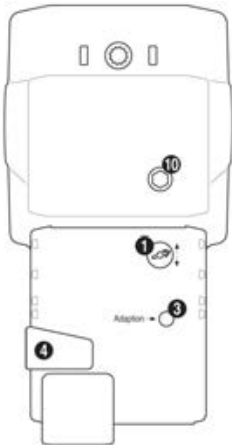

(1) Direction of stroke switch

Switching: Direction of stroke changes

(3) Push-button and LED display yellow

Off: Standard mode

Illuminated: Adaption procedure active

Press button: Triggers stroke adaption, followed by standard mode

(4) Gear disengagement button

Press button: Gear disengages, motor stops, manual override possible

Release button: Gear engages, standard mode

(10) Manual override

Clockwise: Actuator spindle extends

Counterclockwise: Actuator spindle retracts

Dimensions [mm]

Dimensional drawings

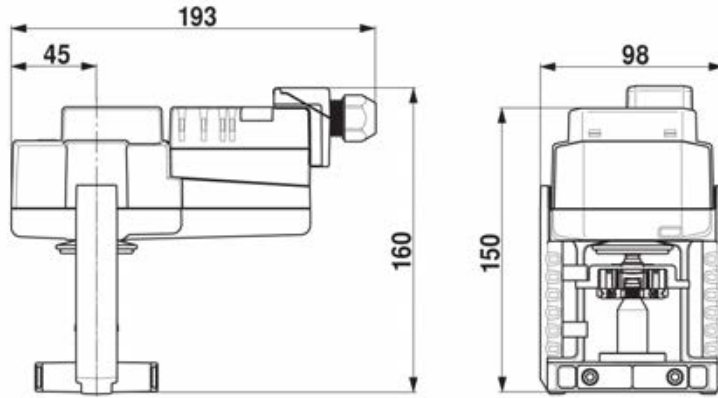

**Communication-capable globe valve actuator
for 2-way and 3-way globe valves**

- Actuating force 1000N
- Nominal voltage AC/DC 24V
- Control modulating DC (0)0.5V...10V, variable
- Nominal stroke 20mm

Technical data

Electrical data	Nominal voltage	AC/DC 24V
	Nominal voltage frequency	50/60Hz
	Nominal voltage range	AC 19.2...28.8V / DC 21.6...28.8V
	Power consumption in operation	3W
	Power consumption in rest position	1.5W
	Power consumption for wire sizing	4.5VA
	Connection supply / control	Terminals 4mm ² and cable 1m, 4 x 0.75mm ²
Functional data	Parallel operation	Yes
	Actuating force	1000N
	Positioning signal Y	DC 0...10V
	Positioning signal Y note	Input impedance 100kΩ
	Operating range Y	DC 0.5...10V
	Operating range Y variable	Start point DC 0.5...30V
		End point DC 2.5...32V
	Position feedback U	DC 0.5...10V
	Position feedback U note	max. 0.5mA
	Position feedback U variable	Start point DC 0.5...8V
		End point DC 2.5...10V
	Position accuracy	5% absolute
	Manual override	Gear disengagement with push-button, can be locked
	Nominal stroke	20mm
	Actuating time	150s/20mm
	Override control MAX (maximum position)	100%
	Override control MIN (minimum position)	0%
	Override control ZS (intermediate position, only AC)	50%
		ZS = MIN...MAX
	Sound power level motor max.	45dB(A)
Sound power level motor note	55dB(A) @ 90s running time	
Position indication	Mechanical 5...20mm stroke	
Safety	Protection class IEC/EN	III Safety extra-low voltage
	Degree of protection IEC/EN	IP54
	EMC	CE in accordance with 2004/108/EC
Certification IEC/EN	Certified to: IEC/EN 60730-1 and IEC/EN 60730-2-14	
Mode of operation	Type 1	
Rated impulse voltage supply / control	0.8kV	
Control pollution degree	3	
Ambient temperature	0°C...50°C	
Non-operating temperature	-40°C...80°C	
Ambient humidity	95% r.h., non-condensing	
Maintenance	Maintenance-free	
Weight	Weight approx.	1.36kg

Safety notes



- This actuator has been designed for application in stationary heating, ventilation and air-conditioning systems and is not allowed to be used outside the specified field of application, especially in aircraft or in any other airborne means of transport.
- Only authorised specialists may carry out installation. All applicable legal or institutional installation regulations must be complied with during installation.
- The switch for changing the direction of motion/the closing point may be adjusted only by authorised personnel. The direction of stroke is critical, particularly in connection with frost protection circuits.
- The device may only be opened at the manufacturer’s site. It does not contain any parts that can be replaced or repaired by the user.
- The device contains electrical and electronic components and is not allowed to be disposed of as household refuse. All locally valid regulations and requirements must be observed.

Product features

Principle of operation	The actuator is connected with a standard modulating signal of DC 0...10V and travels to the position defined by the positioning signal. The measuring voltage U serves for the electrical display of the actuator position 0...100% and as slave control signal for other actuators.
Adjustable-parameter actuators	The factory settings cover the most common applications. Input and output signals and other parameters can be altered with the PC-Tool MFT-P or with the service tool ZTH-GEN.
Direct mounting	Simple direct mounting on the globe valve by means of form-fit hollow clamping jaws. The actuator can be rotated through 360° on the valve neck.
Manual override	Manual override with push-button possible - temporary, permanently. The gear is disengaged and the actuator decoupled for as long as the button is pressed / latched. The stroke can be adjusted by using a hexagon socket screw key (4mm), which is inserted into the top of the actuator. The stroke spindle extends when the key is rotated clockwise.
High functional reliability	The actuator is overload protected, requires no limit switches and automatically stops when the end stop is reached.
Combination valve/actuator	Refer to the valve documentation for suitable valves, their permitted medium temperatures and closing pressures.
Position indication	The stroke is indicated mechanically on the bracket with tabs. The stroke range adjusts itself automatically during operation.
Home position	Setting ex-works: Actuator spindle is retracted. When valve-actuator combinations are shipped, the direction of motion is set in accordance with the closing point of the valve.
Direction of stroke switch	When actuated, the direction of stroke switch changes the running direction in normal operation.
Adaption of stroke range	The first time the supply voltage is switched on, i.e. at the time of commissioning, the actuator carries out a stroke adaption, which is when the operating range and position feedback adjust themselves to the mechanical stroke. Manual triggering of the adaption can be carried out by pressing the “Adaption” button or with the PC-Tool. The actuator then moves into the position defined by the positioning signal.

Accessories

	Description	Type
Electrical accessories	Auxiliary switch add-on, 2 x SPDT	S2A-H
Service tools	Manual parameterising device, for MF/MP/Modbus/LonWorks actuators and VAV-Control	ZTH-GEN
	Belimo PC-Tool, software for adjustments and diagnostics	MFT-P

Electrical installation



Notes • Connection via safety isolating transformer.
 • Parallel connection of other actuators possible.
 • Direction of stroke switch factory setting: Actuator spindle retracted.

Wiring diagrams

AC/DC 24V, modulating

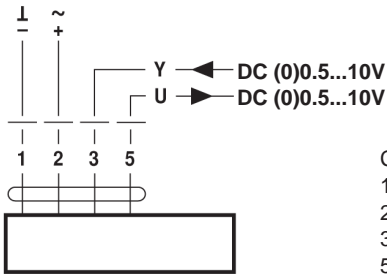

Operation on the MP-Bus

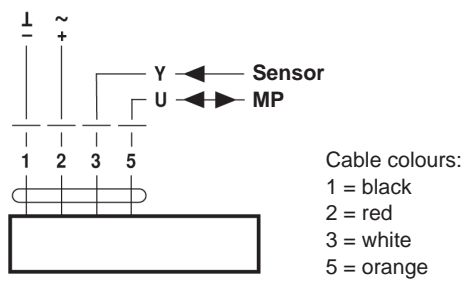

Functions

Functions with basic values

Override control with AC 24V with relay contacts

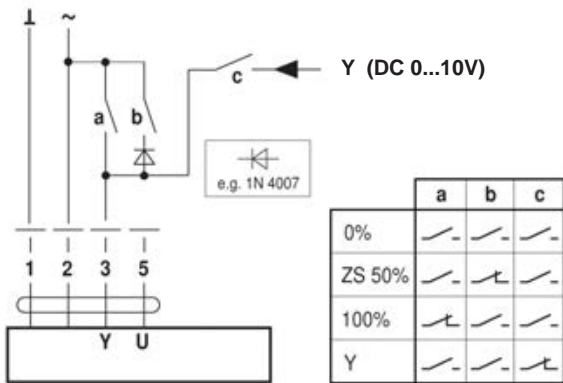

Override control with AC 24V with rotary switch

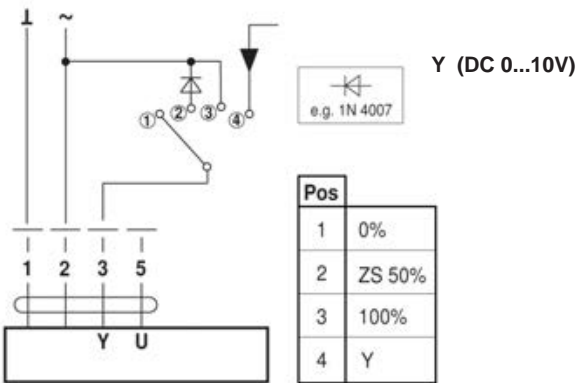

Remote control 0...100%

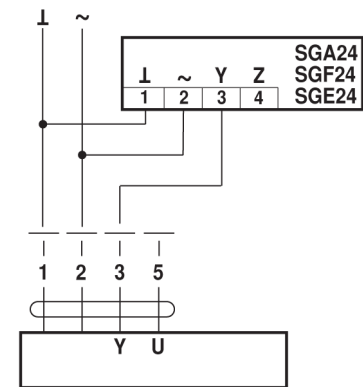

Follow-up control (position-dependent)

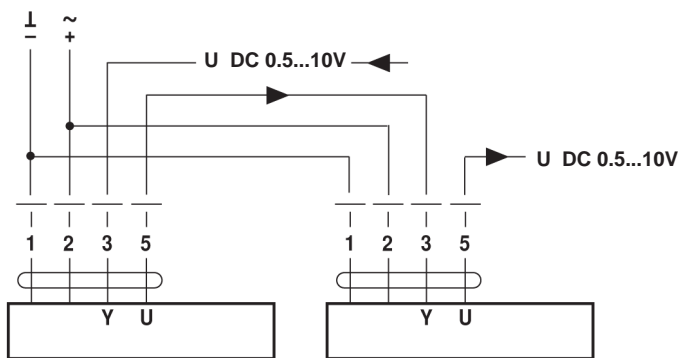

Functions

Control with 4...20mA via external resistor

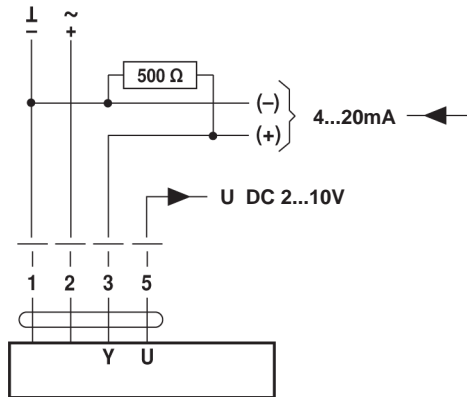

The 500Ω resistor converts the 4...20mA current signal to a voltage signal DC 2...10V

Functions for actuators with specific parameters

Override control and limiting with AC 24V with relay contacts

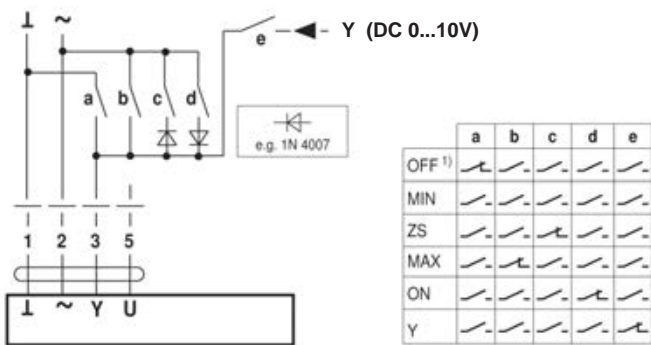

Override control and limiting with AC 24V with rotary switch

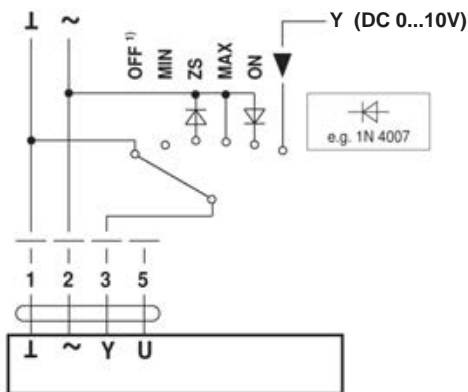

1) Caution: This function is guaranteed only if the start point of the operating range is defined as min. 0.6V.

Functions

AC 24V, 3-point

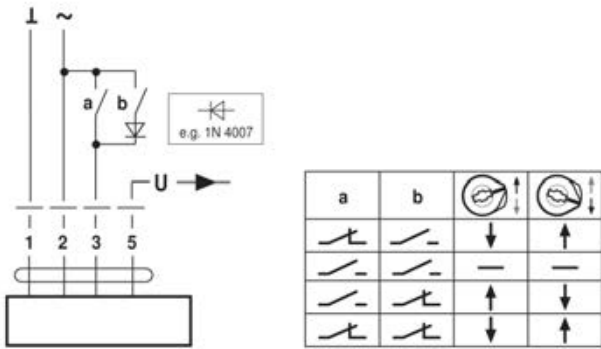

Functions when operated on MP-Bus

Connection on the MP-Bus

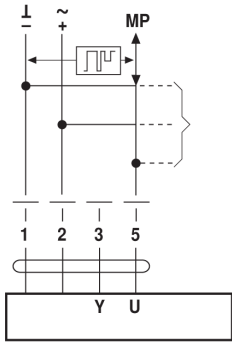

- Supply and communication in one and the same 3-wire cable
- no shielding or twisting required
 - no terminating resistor required

Power topology

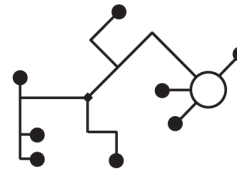

There are no restrictions for the network topology (star, ring, tree or mixed forms are permitted).

Connection of active sensors

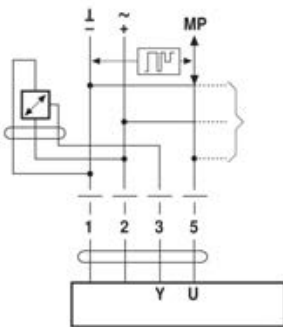

- Supply AC/DC 24A
- Output signal DC 0...10V (max. DC 0...32V)
- Resolution 30mV

Connection of external switching contact

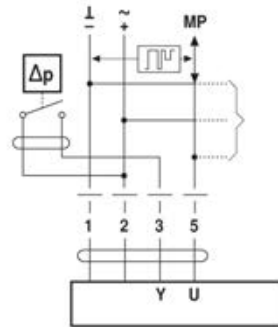

- Switching current 16mA @ 24V
- Start point of the operating range must be parameterised on the MP actuator as $\geq 0.6V$

Connection of passive sensors

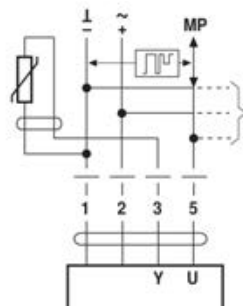

Ni1000	-28 ... +98 °C	850 ... 1600 Ω^2)
PT1000	-35 ... +155 °C	850 ... 1600 Ω^2)
NTC	-10 ... +160 °C ¹⁾	200 Ω ... 50 k Ω^2)

1) Depending on the type
2) Resolution 1 Ohm

Indicators and operating controls

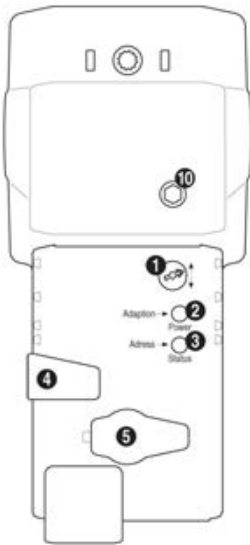

(1) Direction of stroke switch

Switching: Direction of stroke changes

(2) Push-button and LED display green

Off: No power supply or malfunction

Illuminated in green: In operation

Press button: Triggers stroke adaption, followed by standard mode

(3) Push-button and LED display yellow

Off: Standard mode

Flickering: MP communication active

Illuminated: Adaption procedure active

Blinking: Request for addressing from MP master

Press button: Confirmation of addressing

(4) Gear disengagement button

Press button: Gear disengages, motor stops, manual override possible

Release button: Gear engages, standard mode

(5) Service plug

For connecting the parameterisation and service tools

(10) Manual override

Clockwise: Actuator spindle extends

Counterclockwise: Actuator spindle retracts

LED displays (2, green) and (3, yellow)

green: Off; yellow: Illuminated;

Check the supply connections. The phases may have been switched.

Dimensions [mm]

Dimensional drawings

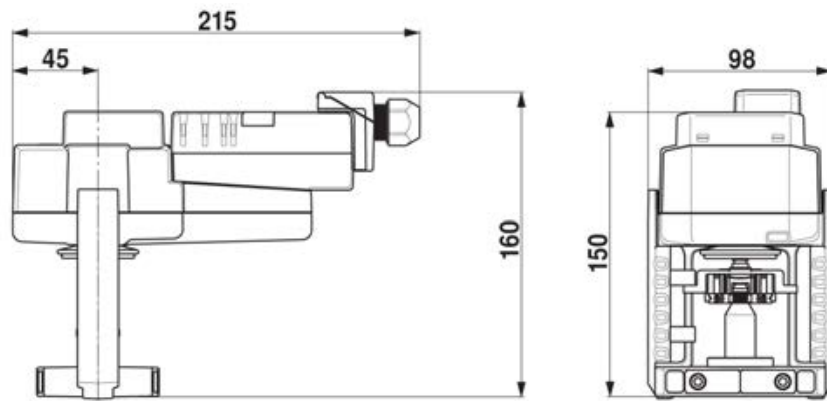

Globe valve actuator for 2-way and 3-way globe valves

- Actuating force 1500N
- Nominal voltage AC/DC 24V
- Control: Open-close, 3-point
- Nominal stroke 20mm

Technical data

Electrical data	Nominal voltage	AC/DC 24V
	Nominal voltage frequency	50/60Hz
	Nominal voltage range	AC 19.2...28.8V / DC 21.6...28.8V
	Power consumption in operation	3W
	Power consumption in rest position	0.5W
	Power consumption for wire sizing	5VA
	Connection supply / control	Terminals 4mm ² and cable 1m, 3 x 0.75mm ²
Functional data	Parallel operation	Yes
	Actuating force	1500N
	Manual override	Gear disengagement with push-button, can be locked
	Nominal stroke	20mm
	Actuating time	150s/20mm
	Sound power level motor max.	35dB(A)
	Position indication	Mechanical 5...20mm stroke
Safety	Protection class IEC/EN	III Safety extra-low voltage
	Degree of protection IEC/EN	IP54
	EMC	CE in accordance with 2004/108/EC
	Certification IEC/EN	Certified to: IEC/EN 60730-1 and IEC/EN 60730-2-14
	Mode of operation	Type 1
	Rated impulse voltage supply / control	0.8kV
	Control pollution degree	3
Weight	Ambient temperature	0°C...50°C
	Non-operating temperature	-40°C...80°C
	Ambient humidity	95% r.h., non-condensing
	Maintenance	Maintenance-free
	Weight approx.	1.34kg

Safety notes

- This actuator has been designed for application in stationary heating, ventilation and air-conditioning systems and is not allowed to be used outside the specified field of application, especially in aircraft or in any other airborne means of transport.
- Only authorised specialists may carry out installation. All applicable legal or institutional installation regulations must be complied with during installation.
- The switch for changing the direction of motion/the closing point may be adjusted only by authorised personnel. The direction of stroke is critical, particularly in connection with frost protection circuits.
- The device may only be opened at the manufacturer's site. It does not contain any parts that can be replaced or repaired by the user.
- The device contains electrical and electronic components and is not allowed to be disposed of as household refuse. All locally valid regulations and requirements must be observed.

Product features

Direct mounting	Simple direct mounting on the globe valve by means of form-fit hollow clamping jaws. The actuator can be rotated through 360° on the valve neck.
Manual override	Manual control with push-button possible - temporary, permanently. The gear is disengaged and the actuator decoupled for as long as the button is pressed / latched. The stroke can be adjusted by using a hexagon socket screw key (4mm), which is inserted into the top of the actuator. The stroke spindle extends when the key is rotated clockwise.
High functional reliability	The actuator is overload protected, requires no limit switches and automatically stops when the end stop is reached.
Combination valve/actuator	Refer to the valve documentation for suitable valves, their permitted medium temperatures and closing pressures.
Position indication	The stroke is indicated mechanically on the bracket with tabs. The stroke range adjusts itself automatically during operation.
Home position	Setting ex-works: Actuator spindle is retracted. When valve-actuator combinations are shipped, the direction of motion is set in accordance with the closing point of the valve.
Direction of stroke switch	When actuated, the direction of stroke switch changes the running direction in normal operation.

Accessories

Electrical accessories

Description

Type

Auxiliary switch

S2A-H

Electrical installation



- Notes
- Connection via safety isolating transformer.
 - Parallel connection of other actuators possible.
 - Direction of stroke switch factory setting: Actuator spindle retracted.

Wiring diagrams

AC/DC 24V, open-close (one-wire)

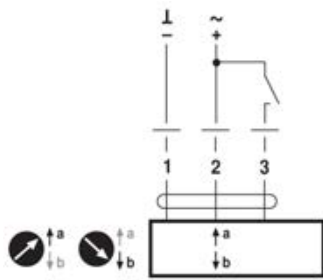

Cable colours:
1 = black
2 = red
3 = white

AC/DC 24V, 3-point

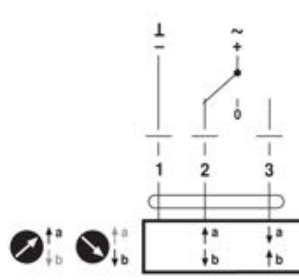

Cable colours:
1 = black
2 = red
3 = white

Indicators and operating controls

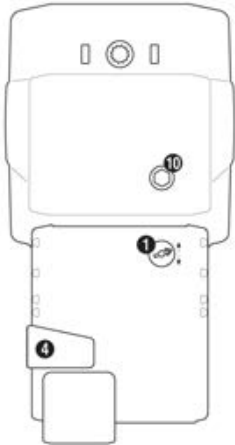

(1) Direction of stroke switch

Switching: Direction of stroke changes

(4) Gear disengagement button

Press button: Gear disengages, motor stops, manual override possible

Release button: Gear engages, standard mode

(10) Manual override

Clockwise: Actuator spindle extends

Counterclockwise: Actuator spindle retracts

Dimensions [mm]

Dimensional drawings

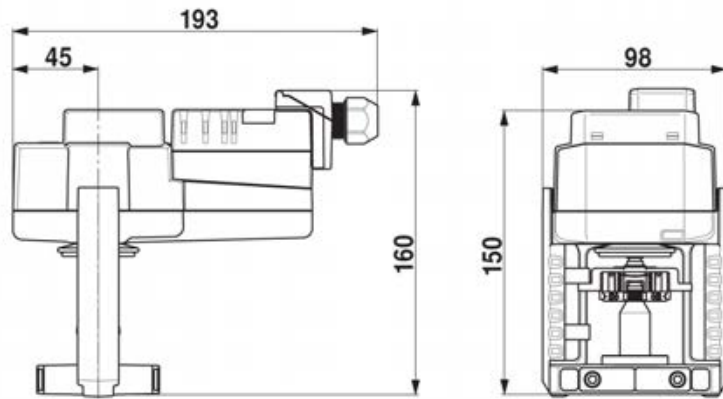

Globe valve actuator for 2-way and 3-way globe valves

- Actuating force 1500N
- Nominal voltage AC 230V
- Control: Open-close, 3-point
- Nominal stroke 20mm

Technical data

Electrical data	Nominal voltage	AC 230V
	Nominal voltage frequency	50/60Hz
	Nominal voltage range	AC 198...264V
	Power consumption in operation	3.5W
	Power consumption in rest position	1W
	Power consumption for wire sizing	6.5VA
	Connection supply / control	Terminals 4mm ² and cable 1m, 3 x 0.75mm ²
	Parallel operation	Yes
Functional data	Actuating force	1500N
	Manual override	Gear disengagement with push-button, can be locked
	Nominal stroke	20mm
	Actuating time	150s/20mm
	Sound power level motor max.	35dB(A)
	Position indication	Mechanical 5...20mm stroke
Safety	Protection class IEC/EN	II Protective insulated
	Degree of protection IEC/EN	IP54
	EMC	CE in accordance with 2004/108/EC
	Certification IEC/EN	Certified to: IEC/EN 60730-1 and IEC/EN 60730-2-14
	Mode of operation	Type 1
	Rated impulse voltage supply / control	4kV
	Control pollution degree	3
	Ambient temperature	0°C...50°C
	Non-operating temperature	-40°C...80°C
	Ambient humidity	95% r.h., non-condensing
	Maintenance	Maintenance-free
	Weight	Weight approx.

Safety notes

- This actuator has been designed for application in stationary heating, ventilation and air-conditioning systems and is not allowed to be used outside the specified field of application, especially in aircraft or in any other airborne means of transport.
- Only authorised specialists may carry out installation. All applicable legal or institutional installation regulations must be complied with during installation.
- The switch for changing the direction of motion/the closing point may be adjusted only by authorised personnel. The direction of stroke is critical, particularly in connection with frost protection circuits.
- The device may only be opened at the manufacturer's site. It does not contain any parts that can be replaced or repaired by the user.
- The device contains electrical and electronic components and is not allowed to be disposed of as household refuse. All locally valid regulations and requirements must be observed.

Product features

Direct mounting	Simple direct mounting on the globe valve by means of form-fit hollow clamping jaws. The actuator can be rotated through 360° on the valve neck.
Manual override	Manual control with push-button possible - temporary, permanently. The gear is disengaged and the actuator decoupled for as long as the button is pressed / latched. The stroke can be adjusted by using a hexagon socket screw key (4mm), which is inserted into the top of the actuator. The stroke spindle extends when the key is rotated clockwise.
High functional reliability	The actuator is overload protected, requires no limit switches and automatically stops when the end stop is reached.
Combination valve/actuator	Refer to the valve documentation for suitable valves, their permitted medium temperatures and closing pressures.
Position indication	The stroke is indicated mechanically on the bracket with tabs. The stroke range adjusts itself automatically during operation.
Home position	Setting ex-works: Actuator spindle is retracted. When valve-actuator combinations are shipped, the direction of motion is set in accordance with the closing point of the valve.
Direction of stroke switch	When actuated, the direction of stroke switch changes the running direction in normal operation.

Accessories

	Description	Type
Electrical accessories	Auxiliary switch	S2A-H

Electrical installation



- Notes
- Parallel connection of other actuators possible.
 - Direction of stroke switch factory setting: Actuator spindle retracted.

Wiring diagrams

AC 230V, open-close (one-wire)

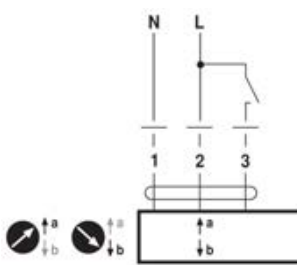

Cable colours:
1 = blue
2 = brown
3 = white

AC 230V, 3-point

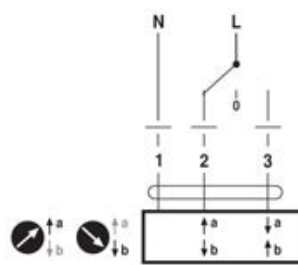

Cable colours:
1 = blue
2 = brown
3 = white

Indicators and operating controls

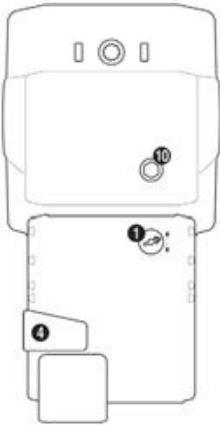

(1) Direction of stroke switch

Switching: Direction of stroke changes

(4) Gear disengagement button

Press button: Gear disengages, motor stops, manual override possible

Release button: Gear engages, standard mode

(10) Manual override

Clockwise: Actuator spindle extends

Counterclockwise: Actuator spindle retracts

Dimensions [mm]

Dimensional drawings

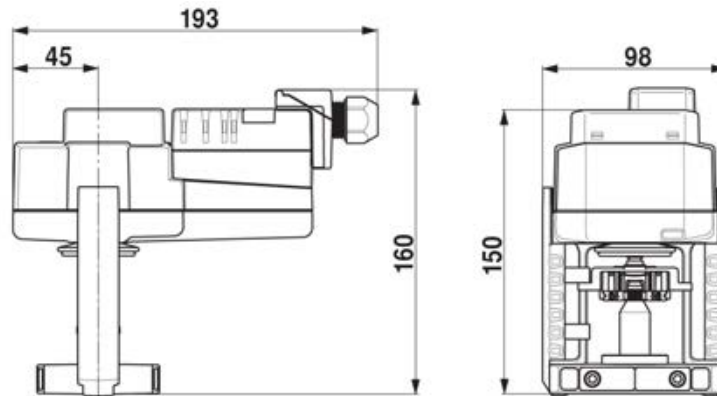

Modulating globe valve actuator for 2-way and 3-way globe valves

- Actuating force 1500N
- Nominal voltage AC/DC 24V
- Control: modulating DC (0)0.5V...10V
- Nominal stroke 20mm

Technical data

Electrical data	Nominal voltage	AC/DC 24V
	Nominal voltage frequency	50/60Hz
	Nominal voltage range	AC 19.2...28.8V / DC 21.6...28.8V
	Power consumption in operation	2W
	Power consumption in rest position	1.5W
	Power consumption for wire sizing	3.5VA
	Connection supply / control	Terminals 4mm ² and cable 1m, 4 x 0.75mm ²
Functional data	Parallel operation	Yes
	Actuating force	1500N
	Positioning signal Y	DC 0...10V
	Positioning signal Y note	Input impedance 100kΩ
	Operating range Y	DC 0.5...10V
	Position feedback U	DC 0.5...10V
	Position feedback U note	max. 0.5mA
	Position accuracy	5% absolute
	Manual override	Gear disengagement with push-button, can be locked
	Nominal stroke	20mm
	Actuating time	150s/20mm
	Sound power level motor max.	35dB(A)
	Safety	Position indication
Protection class IEC/EN		III Safety extra-low voltage
Degree of protection IEC/EN		IP54
EMC		CE in accordance with 2004/108/EC
Certification IEC/EN		Certified to: IEC/EN 60730-1 and IEC/EN 60730-2-14
Mode of operation		Type 1
Rated impulse voltage supply / control		0.8kV
Control pollution degree		3
Ambient temperature		0°C...50°C
Non-operating temperature		-40°C...80°C
Weight	Ambient humidity	95% r.h., non-condensing
	Maintenance	Maintenance-free
	Weight approx.	1.39kg

Safety notes

- This actuator has been designed for application in stationary heating, ventilation and air-conditioning systems and is not allowed to be used outside the specified field of application, especially in aircraft or in any other airborne means of transport.
- Only authorised specialists may carry out installation. All applicable legal or institutional installation regulations must be complied with during installation.
- The switch for changing the direction of motion/the closing point may be adjusted only by authorised personnel. The direction of stroke is critical, particularly in connection with frost protection circuits.
- The device may only be opened at the manufacturer's site. It does not contain any parts that can be replaced or repaired by the user.

Safety notes

- The device contains electrical and electronic components and is not allowed to be disposed of as household refuse. All locally valid regulations and requirements must be observed.

Product features

Principle of operation	The actuator is connected with a standard modulating signal of DC 0...10V and travels to the position defined by the positioning signal. The measuring voltage U serves for the electrical display of the actuator position 0...100% and as slave control signal for other actuators.
Direct mounting	Simple direct mounting on the globe valve by means of form-fit hollow clamping jaws. The actuator can be rotated through 360° on the valve neck.
Manual override	Manual override with push-button possible - temporary, permanently. The gear is disengaged and the actuator decoupled for as long as the button is pressed / latched. The stroke can be adjusted by using a hexagon socket screw key (4mm), which is inserted into the top of the actuator. The stroke spindle extends when the key is rotated clockwise.
High functional reliability	The actuator is overload protected, requires no limit switches and automatically stops when the end stop is reached.
Combination valve/actuator	Refer to the valve documentation for suitable valves, their permitted medium temperatures and closing pressures.
Position indication	The stroke is indicated mechanically on the bracket with tabs. The stroke range adjusts itself automatically during operation.
Home position	Setting ex-works: Actuator spindle is retracted. When valve-actuator combinations are shipped, the direction of motion is set in accordance with the closing point of the valve.
Direction of stroke switch	When actuated, the direction of stroke switch changes the running direction in normal operation.
Adaption of stroke range	The first time the supply voltage is switched on, i.e. at the time of commissioning, the actuator carries out a stroke adaption, which is when the operating range and position feedback adjust themselves to the mechanical stroke. Manual triggering of the adaption can be carried out by pressing the "Adaption" button. The actuator then moves into the position defined by the positioning signal.

Accessories

	Description	Type
Electrical accessories	Auxiliary switch add-on, 2 x SPDT	S2A-H

Electrical installation



- Notes
- Connection via safety isolating transformer.
 - Parallel connection of other actuators possible
 - Direction of stroke switch factory setting: Actuator spindle retracted.

Wiring diagrams

AC/DC 24V, modulating

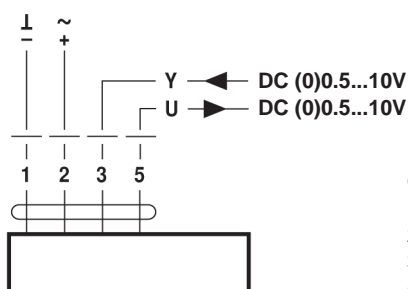

Indicators and operating controls

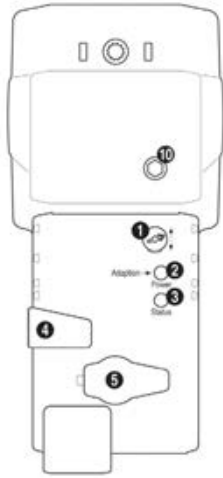

- (1) Direction of stroke switch**
Switching: Direction of stroke changes
- (2) Push-button and LED display green**
Off: No power supply or malfunction
Illuminated: In operation
Press button: Triggers stroke adaption, followed by standard mode
- (3) LED display yellow**
Off: Standard mode
Illuminated: Adaption procedure active
- (4) Gear disengagement button**
Press button: Gear disengages, motor stops, manual override possible
Release button: Gear engages, standard mode
- (5) Service plug**
No function
- (10) Manual override**
Clockwise: Actuator spindle extends
Counterclockwise: Actuator spindle retracts

Dimensions [mm]

Dimensional drawings

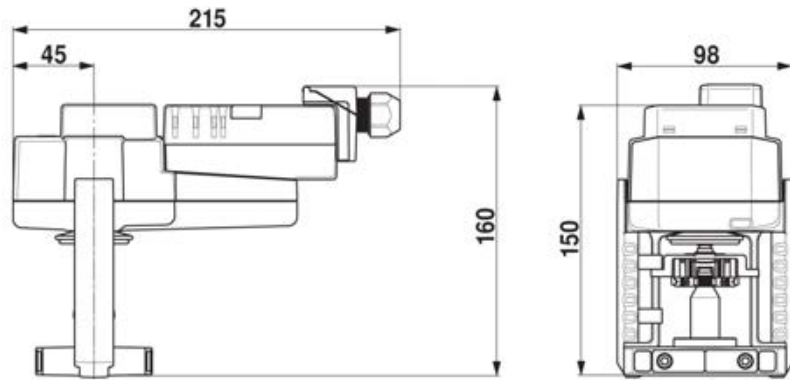

**Communication-capable globe valve actuator
for 2-way and 3-way globe valves**

- Actuating force 1500N
- Nominal voltage AC/DC 24V
- Control modulating DC (0)0.5V...10V, variable
- Nominal stroke 20mm



Technical data

Electrical data	Nominal voltage	AC/DC 24V
	Nominal voltage frequency	50/60Hz
	Nominal voltage range	AC 19.2...28.8V / DC 21.6...28.8V
	Power consumption in operation	2W
	Power consumption in rest position	1.5W
	Power consumption for wire sizing	3.5VA
	Connection supply / control	Terminals 4mm ² and cable 1m, 4 x 0.75mm ²
Functional data	Parallel operation	Yes
	Actuating force	1500N
	Positioning signal Y	DC 0...10V
	Positioning signal Y note	Input impedance 100kΩ
	Operating range Y	DC 0.5...10V
	Operating range Y variable	Start point DC 0.5...30V
		End point DC 2.5...32V
	Position feedback U	DC 0.5...10V
	Position feedback U note	max. 0.5mA
	Position feedback U variable	Start point DC 0.5...8V
		End point DC 2.5...10V
	Position accuracy	5% absolute
	Manual override	Gear disengagement with push-button, can be locked
	Nominal stroke	20mm
	Actuating time	150s/20mm
	Override control MAX (maximum position)	100%
	Override control MIN (minimum position)	0%
	Override control ZS (intermediate position, only AC)	50%
		Override control ZS variable
	Sound power level motor max.	35dB(A)
	Sound power level motor note	45dB(A) @ 90s running time
Position indication	Mechanical 5...20mm stroke	
Safety	Protection class IEC/EN	III Safety extra-low voltage
	Degree of protection IEC/EN	IP54
EMC	CE in accordance with 2004/108/EC	
Certification IEC/EN	Certified to: IEC/EN 60730-1 and IEC/EN 60730-2-14	
Mode of operation	Type 1	
Rated impulse voltage supply / control	0.8kV	
Control pollution degree	3	
Ambient temperature	0°C...50°C	
Non-operating temperature	-40°C...80°C	
Ambient humidity	95% r.h., non-condensing	
Maintenance	Maintenance-free	
Weight	Weight approx.	1.39kg

Safety notes



- This actuator has been designed for application in stationary heating, ventilation and air-conditioning systems and is not allowed to be used outside the specified field of application, especially in aircraft or in any other airborne means of transport.
- Only authorised specialists may carry out installation. All applicable legal or institutional installation regulations must be complied with during installation.
- The switch for changing the direction of motion/the closing point may be adjusted only by authorised personnel. The direction of stroke is critical, particularly in connection with frost protection circuits.
- The device may only be opened at the manufacturer's site. It does not contain any parts that can be replaced or repaired by the user.
- The device contains electrical and electronic components and is not allowed to be disposed of as household refuse. All locally valid regulations and requirements must be observed.

Product features

Principle of operation

The actuator is connected with a standard modulating signal of DC 0...10V and travels to the position defined by the positioning signal. The measuring voltage U serves for the electrical display of the actuator position 0...100% and as slave control signal for other actuators.

Adjustable-parameter actuators

The factory settings cover the most common applications. Input and output signals and other parameters can be altered with the PC-Tool MFT-P or with the service tool ZTH-GEN.

Direct mounting

Simple direct mounting on the globe valve by means of form-fit hollow clamping jaws. The actuator can be rotated through 360° on the valve neck.

Manual override

Manual override with push-button possible - temporary, permanently. The gear is disengaged and the actuator decoupled for as long as the button is pressed / latched. The stroke can be adjusted by using a hexagon socket screw key (4mm), which is inserted into the top of the actuator. The stroke spindle extends when the key is rotated clockwise.

High functional reliability

The actuator is overload protected, requires no limit switches and automatically stops when the end stop is reached.

Combination valve/actuator

Refer to the valve documentation for suitable valves, their permitted medium temperatures and closing pressures.

Position indication

The stroke is indicated mechanically on the bracket with tabs. The stroke range adjusts itself automatically during operation.

Home position

Setting ex-works: Actuator spindle is retracted.
When valve-actuator combinations are shipped, the direction of motion is set in accordance with the closing point of the valve.

Direction of stroke switch

When actuated, the direction of stroke switch changes the running direction in normal operation.

Adaption of stroke range

The first time the supply voltage is switched on, i.e. at the time of commissioning, the actuator carries out a stroke adaption, which is when the operating range and position feedback adjust themselves to the mechanical stroke.

Manual triggering of the adaption can be carried out by pressing the "Adaption" button or with the PC-Tool.

The actuator then moves into the position defined by the positioning signal.

Accessories

	Description	Type
Electrical accessories	Auxiliary switch add-on, 2 x SPDT	S2A-H
Service tools	Manual parameterising device, for MF/MP/Modbus/LonWorks actuators and VAV-Control	ZTH-GEN
	Belimo PC-Tool, software for adjustments and diagnostics	MFT-P

Electrical installation



- Notes
- Connection via safety isolating transformer.
 - Parallel connection of other actuators possible.
 - Direction of stroke switch factory setting: Actuator spindle retracted.

Wiring diagrams

AC/DC 24V, modulating

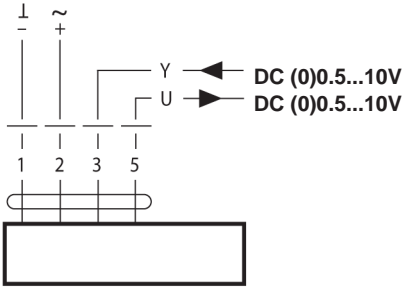

Operation on the MP-Bus

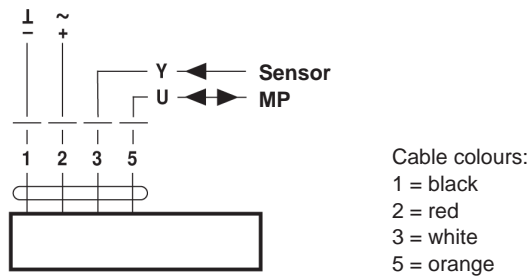

Functions

Functions with basic values

Override control with AC 24V with relay contacts

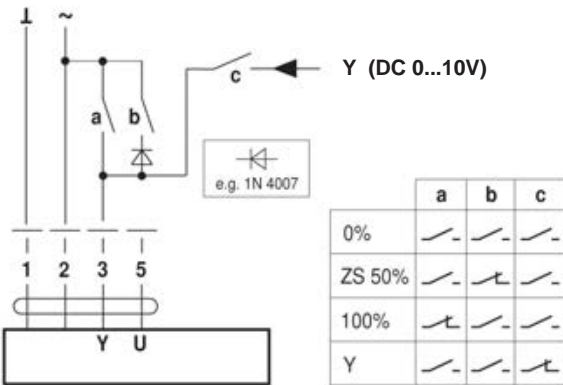

Override control with AC 24V with rotary switch

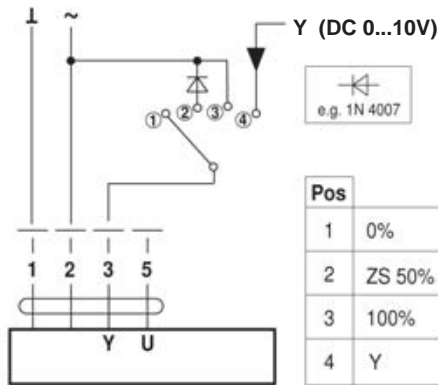

Remote control 0...100%

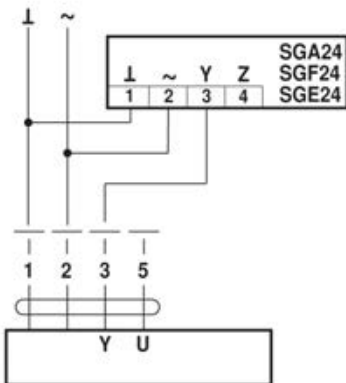

Follow-up control (position-dependent)

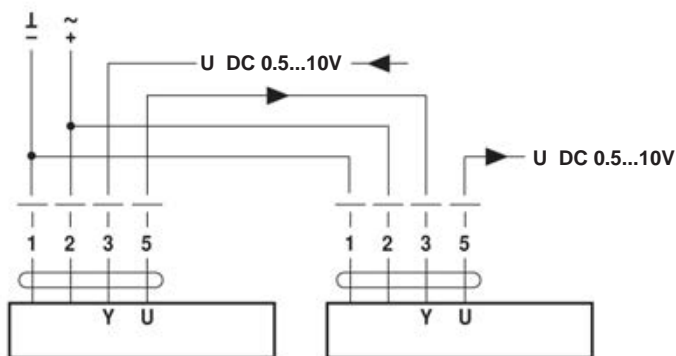

Functions

Control with 4...20mA via external resistor

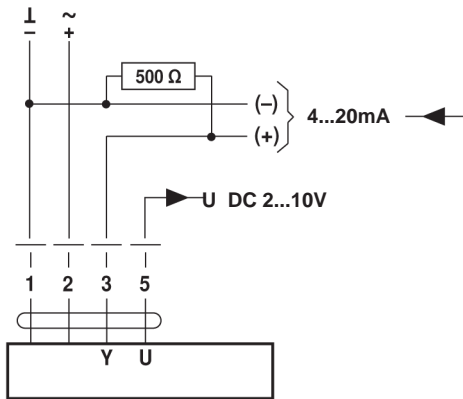

The 500Ω resistor converts the 4...20mA current signal to a voltage signal DC 2...10V

Functions for actuators with specific parameters

Override control and limiting with AC 24V with relay contacts

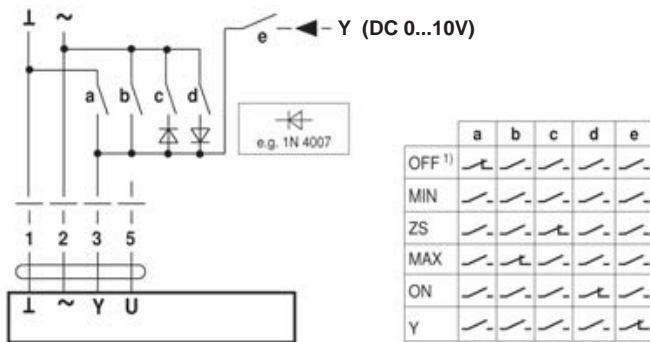

Override control and limiting with AC 24V with rotary switch

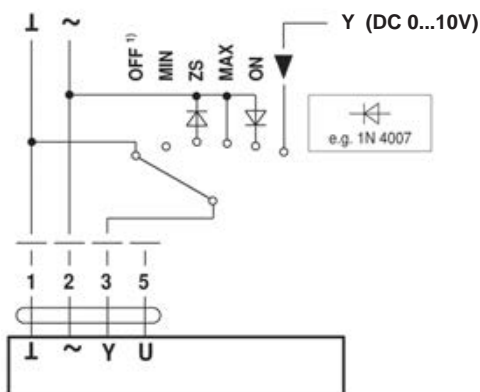

1) Caution: This function is guaranteed only if the start point of the operating range is defined as min. 0.6V.

Functions

AC 24V, 3-point

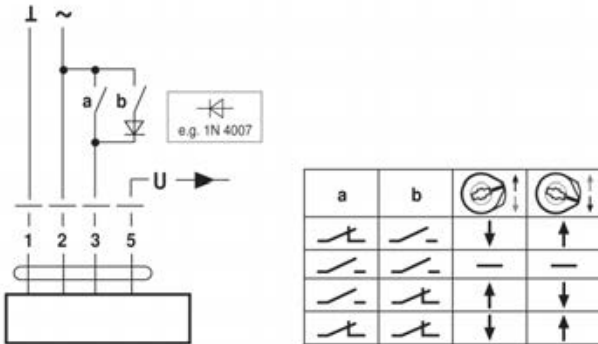

Functions when operated on MP-Bus

Connection on the MP-Bus

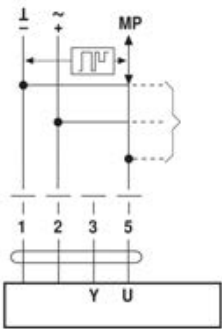

- Supply and communication in one and the same 3-wire cable
- no shielding or twisting required
 - no terminating resistor required

Power topology

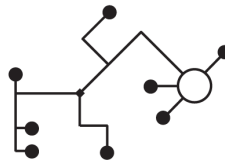

There are no restrictions for the network topology (star, ring, tree or mixed forms are permitted).

Connection of active sensors

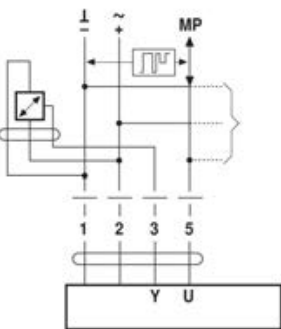

- Supply AC/DC 24A
- Output signal DC 0...10V (max. DC 0...32V)
- Resolution 30mV

Connection of external switching contact

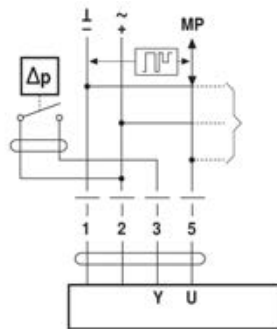

- Switching current 16mA @ 24V
- Start point of the operating range must be parameterised on the MP actuator as $\geq 0.6V$

Connection of passive sensors

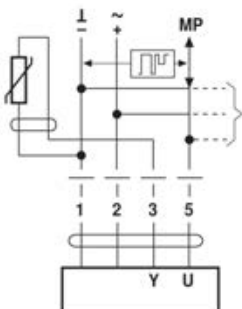

Ni1000	-28 ... +98 °C	850 ... 1600 Ω^2)
PT1000	-35 ... +155 °C	850 ... 1600 Ω^2)
NTC	-10 ... +160 °C ¹⁾	200 Ω ... 50 k Ω^2)

- 1) Depending on the type
2) Resolution 1 Ohm

Indicators and operating controls

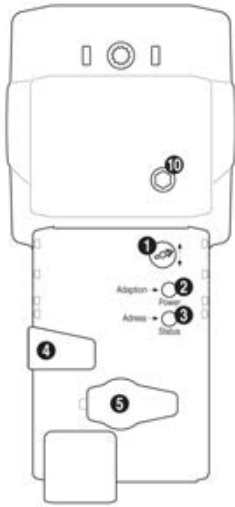

- (1) Direction of stroke switch**
Switching: Direction of stroke changes
 - (2) Push-button and LED display green**
Off: No power supply or malfunction
Illuminated in green: In operation
Press button: Triggers stroke adaption, followed by standard mode
 - (3) Push-button and LED display yellow**
Off: Standard mode
Flickering: MP communication active
Illuminated: Adaption procedure active
Blinking: Request for addressing from MP master
Press button: Confirmation of addressing
 - (4) Gear disengagement button**
Press button: Gear disengages, motor stops, manual override possible
Release button: Gear engages, standard mode
 - (5) Service plug**
For connecting the parameterisation and service tools
 - (10) Manual override**
Clockwise: Actuator spindle extends
Counterclockwise: Actuator spindle retracts
- LED displays (2, green) and (3, yellow)**
green: Off; yellow: Illuminated;
Check the supply connections. The phases may have been switched.

Dimensions [mm]

Dimensional drawings

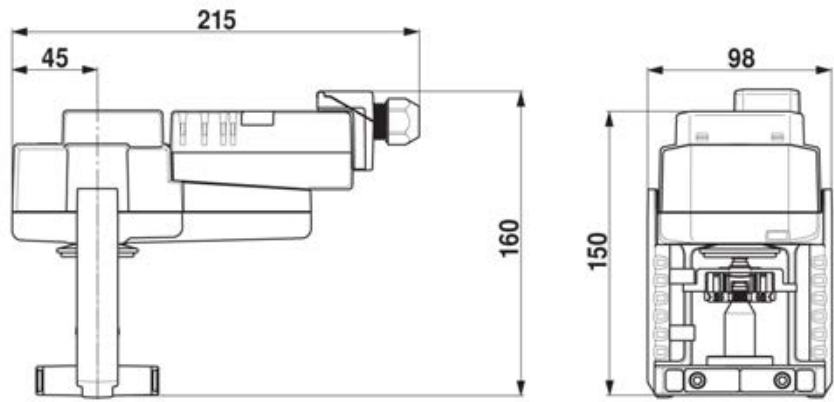

Globe valve actuator for 2-way and 3-way globe valves

- Actuating force 2500N
- Nominal voltage AC/DC 24V
- Control: Open-close, 3-point
- Nominal stroke 40mm

Technical data

Electrical data	Nominal voltage	AC/DC 24V	
	Nominal voltage frequency	50/60Hz	
	Nominal voltage range	AC 19.2...28.8V / DC 21.6...28.8V	
	Power consumption in operation	2.5W	
	Power consumption in rest position	0.5W	
	Power consumption for wire sizing	4.5VA	
	Connection supply / control	Terminals 4mm ² and cable 1m, 3 x 0.75mm ²	
	Parallel operation	Yes	
Functional data	Actuating force	2500N	
	Manual override	Gear disengagement with push-button, can be locked	
	Nominal stroke	40mm	
	Actuating time	150s/40mm	
	Sound power level motor max.	55dB(A)	
	Position indication	Mechanical 5...40mm stroke	
Safety	Protection class IEC/EN	III Safety extra-low voltage	
	Degree of protection IEC/EN	IP54	
	EMC	CE in accordance with 2004/108/EC	
	Certification IEC/EN	Certified to: IEC/EN 60730-1 and IEC/EN 60730-2-14	
	Mode of operation	Type 1	
	Rated impulse voltage supply / control	0.8kV	
	Control pollution degree	3	
	Ambient temperature	0°C...50°C	
	Non-operating temperature	-40°C...80°C	
	Ambient humidity	95% r.h., non-condensing	
	Maintenance	Maintenance-free	
	Weight	Weight approx.	4.22kg

Safety notes

- This actuator has been designed for application in stationary heating, ventilation and air-conditioning systems and is not allowed to be used outside the specified field of application, especially in aircraft or in any other airborne means of transport.
- Only authorised specialists may carry out installation. All applicable legal or institutional installation regulations must be complied with during installation.
- The switch for changing the direction of motion/the closing point may be adjusted only by authorised personnel. The direction of stroke is critical, particularly in connection with frost protection circuits.
- The device may only be opened at the manufacturer's site. It does not contain any parts that can be replaced or repaired by the user.
- The device contains electrical and electronic components and is not allowed to be disposed of as household refuse. All locally valid regulations and requirements must be observed.

Product features

Direct mounting	Simple direct mounting on the globe valve by means of form-fit hollow clamping jaws. The actuator can be rotated through 360° on the valve neck.
Manual override	Manual override with push-button possible - temporary, permanently. The gear is disengaged and the actuator decoupled for as long as the button is pressed / engaged. The stroke can be adjusted by using a hexagon socket screw key (5mm), which is inserted into the top of the actuator. The stroke spindle extends when the key is rotated clockwise.
High functional reliability	The actuator is overload protected, requires no limit switches and automatically stops when the end stop is reached.
Combination valve/actuator	Refer to the valve documentation for suitable valves, their permitted medium temperatures and closing pressures.
Position indication	The stroke is indicated mechanically on the bracket with tabs. The stroke range adjusts itself automatically during operation.
Home position	Setting ex-works: Actuator spindle is retracted. When valve-actuator combinations are shipped, the direction of motion is set in accordance with the closing point of the valve.
Direction of stroke switch	When actuated, the direction of stroke switch changes the running direction in normal operation.

Accessories

	Description	Type
Electrical accessories	Auxiliary switch	S2A-H

Electrical installation



- Notes
- Connection via safety isolating transformer.
 - Parallel connection of other actuators possible.
 - Direction of stroke switch factory setting: Actuator spindle retracted.

Wiring diagrams

AC/DC 24V, open-close (one-wire)

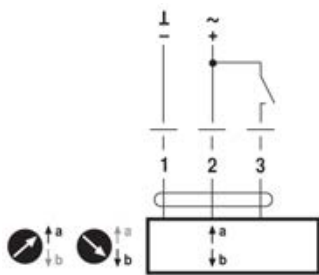

Cable colours:
1 = black
2 = red
3 = white

AC/DC 24V, 3-point

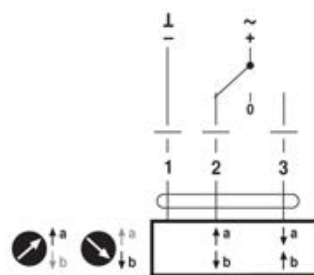

Cable colours:
1 = black
2 = red
3 = white

Indicators and operating controls

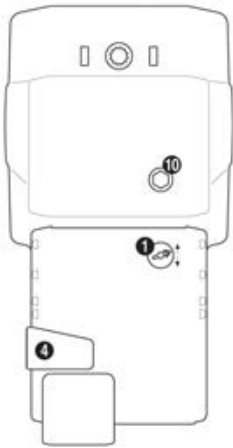

(1) Direction of stroke switch

Switching: Direction of stroke changes

(4) Gear disengagement button

Press button: Gear disengages, motor stops, manual override possible

Release button: Gear engages, standard mode

(10) Manual override

Clockwise: Actuator spindle extends

Counterclockwise: Actuator spindle retracts

Dimensions [mm]

Dimensional drawings

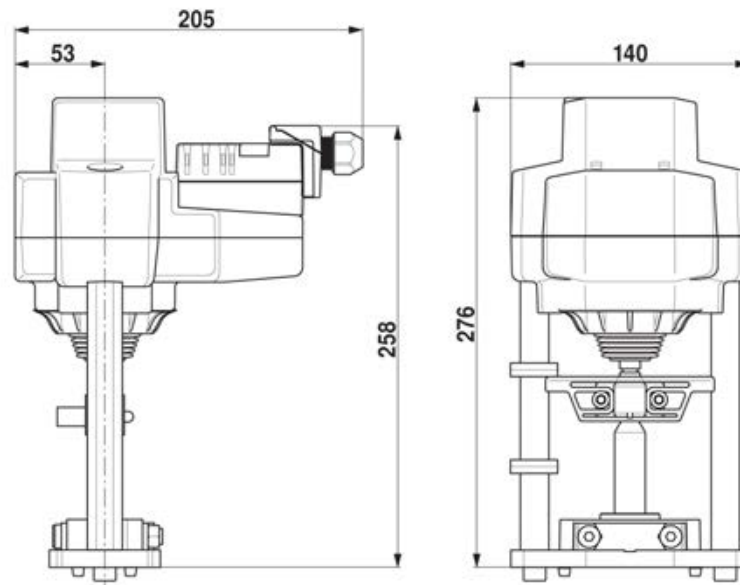

Globe valve actuator for 2-way and 3-way globe valves

- Actuating force 2500N
- Nominal voltage AC 230V
- Control: Open-close, 3-point
- Nominal stroke 40mm

Technical data

Electrical data	Nominal voltage	AC 230V
	Nominal voltage frequency	50/60Hz
	Nominal voltage range	AC 198...264V
	Power consumption in operation	5.5W
	Power consumption in rest position	1W
	Power consumption for wire sizing	9.5VA
	Connection supply / control	Terminals 4mm ² and cable 1m, 3 x 0.75mm ²
Functional data	Parallel operation	Yes
	Actuating force	2500N
	Manual override	Gear disengagement with push-button, can be locked
	Nominal stroke	40mm
	Actuating time	150s/40mm
	Sound power level motor max.	55dB(A)
	Position indication	Mechanical 5...40mm stroke
Safety	Protection class IEC/EN	II Protective insulated
	Degree of protection IEC/EN	IP54
	EMC	CE in accordance with 2004/108/EC
	Certification IEC/EN	Certified to: IEC/EN 60730-1 and IEC/EN 60730-2-14
	Mode of operation	Type 1
	Rated impulse voltage supply / control	4kV
	Control pollution degree	3
Weight	Ambient temperature	0°C...50°C
	Non-operating temperature	-40°C...80°C
	Ambient humidity	95% r.h., non-condensing
	Maintenance	Maintenance-free
	Weight approx.	4.25kg

Safety notes

- This actuator has been designed for application in stationary heating, ventilation and air-conditioning systems and is not allowed to be used outside the specified field of application, especially in aircraft or in any other airborne means of transport.
- Only authorised specialists may carry out installation. All applicable legal or institutional installation regulations must be complied with during installation.
- The switch for changing the direction of motion/the closing point may be adjusted only by authorised personnel. The direction of stroke is critical, particularly in connection with frost protection circuits.
- The device may only be opened at the manufacturer's site. It does not contain any parts that can be replaced or repaired by the user.
- The device contains electrical and electronic components and is not allowed to be disposed of as household refuse. All locally valid regulations and requirements must be observed.

Product features

Direct mounting	Simple direct mounting on the globe valve by means of form-fit hollow clamping jaws. The actuator can be rotated through 360° on the valve neck.
Manual override	Manual override with push-button possible - temporary, permanently. The gear is disengaged and the actuator decoupled for as long as the button is pressed / engaged. The stroke can be adjusted by using a hexagon socket screw key (5mm), which is inserted into the top of the actuator. The stroke spindle extends when the key is rotated clockwise.
High functional reliability	The actuator is overload protected, requires no limit switches and automatically stops when the end stop is reached.
Combination valve/actuator	Refer to the valve documentation for suitable valves, their permitted medium temperatures and closing pressures.
Position indication	The stroke is indicated mechanically on the bracket with tabs. The stroke range adjusts itself automatically during operation.
Home position	Setting ex-works: Actuator spindle is retracted. When valve-actuator combinations are shipped, the direction of motion is set in accordance with the closing point of the valve.
Direction of stroke switch	When actuated, the direction of stroke switch changes the running direction in normal operation.

Accessories

Electrical accessories

Description

Type

Auxiliary switch

S2A-H

Electrical installation



- Notes
- Parallel connection of other actuators possible.
 - Direction of stroke switch factory setting: Actuator spindle retracted.

Wiring diagrams

AC 230V, open-close (one-wire)

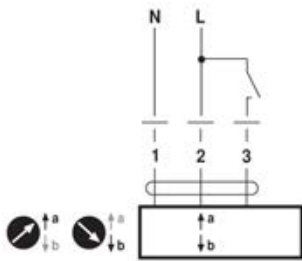

Cable colours:
1 = blue
2 = brown
3 = white

AC 230V, 3-point

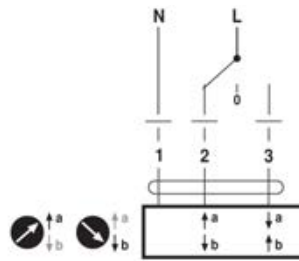

Cable colours:
1 = blue
2 = brown
3 = white

Indicators and operating controls

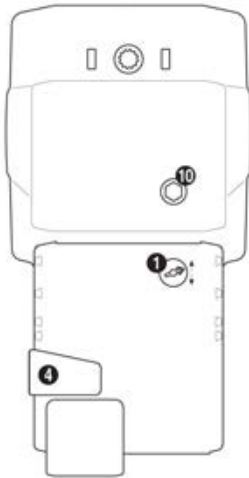

(1) Direction of stroke switch

Switching: Direction of stroke changes

(4) Gear disengagement button

Press button: Gear disengages, motor stops, manual override possible

Release button: Gear engages, standard mode

(10) Manual override

Clockwise: Actuator spindle extends

Counterclockwise: Actuator spindle retracts

Dimensions [mm]

Dimensional drawings

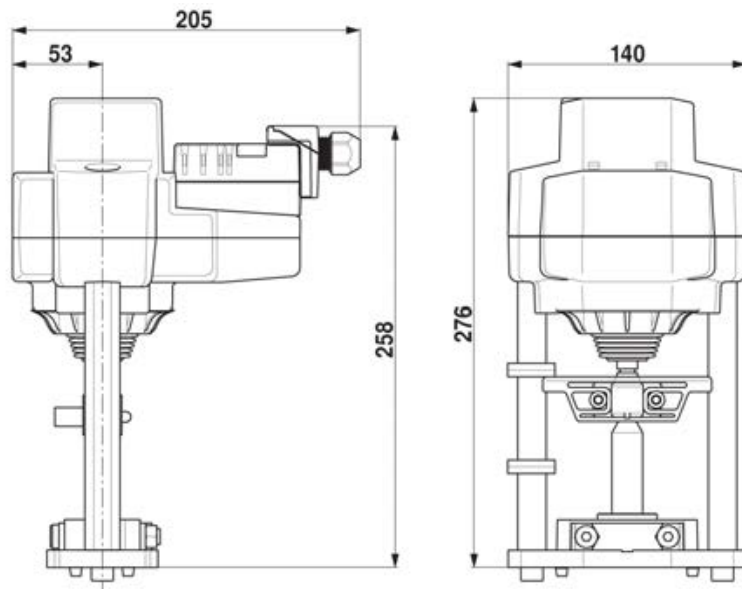

Modulating globe valve actuator for 2-way and 3-way globe valves

- Actuating force 2500N
- Nominal voltage AC/DC 24V
- Control: modulating DC (0)0.5V...10V
- Nominal stroke 40mm



Technical data

Electrical data	Nominal voltage	AC/DC 24V
	Nominal voltage frequency	50/60Hz
	Nominal voltage range	AC 19.2...28.8V / DC 21.6...28.8V
	Power consumption in operation	4W
	Power consumption in rest position	1.5W
	Power consumption for wire sizing	6VA
	Connection supply / control	Terminals 4mm ² and cable 1m, 4 x 0.75mm ²
Functional data	Parallel operation	Yes
	Actuating force	2500N
	Positioning signal Y	DC 0...10V
	Positioning signal Y note	Input impedance 100kΩ
	Operating range Y	DC 0.5...10V
	Position feedback U	DC 0.5...10V
	Position feedback U note	max. 0.5mA
	Position accuracy	5% absolute
	Manual override	Gear disengagement with push-button, can be locked
	Nominal stroke	40mm
	Actuating time	150s/40mm
	Sound power level motor max.	55dB(A)
	Safety	Position indication
Protection class IEC/EN		III Safety extra-low voltage
Degree of protection IEC/EN		IP54
EMC		CE in accordance with 2004/108/EC
Certification IEC/EN		Certified to: IEC/EN 60730-1 and IEC/EN 60730-2-14
Mode of operation		Type 1
Rated impulse voltage supply / control		0.8kV
Control pollution degree		3
Ambient temperature		0°C...50°C
Non-operating temperature		-40°C...80°C
Weight	Ambient humidity	95% r.h., non-condensing
	Maintenance	Maintenance-free
	Weight approx.	4.32kg

Safety notes



- This actuator has been designed for application in stationary heating, ventilation and air-conditioning systems and is not allowed to be used outside the specified field of application, especially in aircraft or in any other airborne means of transport.
- Only authorised specialists may carry out installation. All applicable legal or institutional installation regulations must be complied with during installation.
- The switch for changing the direction of motion/the closing point may be adjusted only by authorised personnel. The direction of stroke is critical, particularly in connection with frost protection circuits.
- The device may only be opened at the manufacturer's site. It does not contain any parts that can be replaced or repaired by the user.

Safety notes

- The device contains electrical and electronic components and is not allowed to be disposed of as household refuse. All locally valid regulations and requirements must be observed.

Product features

Principle of operation	The actuator is connected with a standard modulating signal of DC 0...10V and travels to the position defined by the positioning signal. The measuring voltage U serves for the electrical display of the actuator position 0...100% and as slave control signal for other actuators.
Direct mounting	Simple direct mounting on the globe valve by means of form-fit hollow clamping jaws. The actuator can be rotated through 360° on the valve neck.
Manual override	Manual override with push-button possible - temporary, permanently. The gear is disengaged and the actuator decoupled for as long as the button is pressed / latched. The stroke can be adjusted by using a hexagon socket screw key (5mm), which is inserted into the top of the actuator. The stroke spindle extends when the key is rotated clockwise.
High functional reliability	The actuator is overload protected, requires no limit switches and automatically stops when the end stop is reached.
Combination valve/actuator	Refer to the valve documentation for suitable valves, their permitted medium temperatures and closing pressures.
Position indication	The stroke is indicated mechanically on the bracket with tabs. The stroke range adjusts itself automatically during operation.
Home position	Setting ex-works: Actuator spindle is retracted. When valve-actuator combinations are shipped, the direction of motion is set in accordance with the closing point of the valve.
Direction of stroke switch	When actuated, the direction of stroke switch changes the running direction in normal operation.
Adaption of stroke range	The first time the supply voltage is switched on, i.e. at the time of commissioning, the actuator carries out a stroke adaption, which is when the operating range and position feedback adjust themselves to the mechanical stroke. Manual triggering of the adaption can be carried out by pressing the "Adaption" button. The actuator then moves into the position defined by the positioning signal.

Accessories

	Description	Type
Electrical accessories	Auxiliary switch add-on, 2 x SPDT	S2A-H

Electrical installation

Notes

- Connection via safety isolating transformer.
- Parallel connection of other actuators possible
- Direction of stroke switch factory setting: Actuator spindle retracted.

AC/DC 24V, modulating

Wiring diagrams

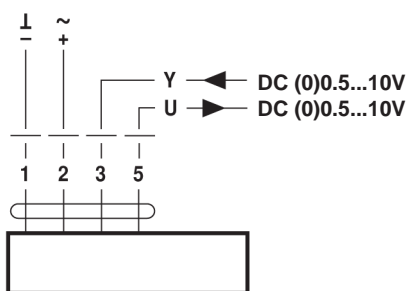

Cable colours:
 1 = black
 2 = red
 3 = white
 5 = orange

Indicators and operating controls

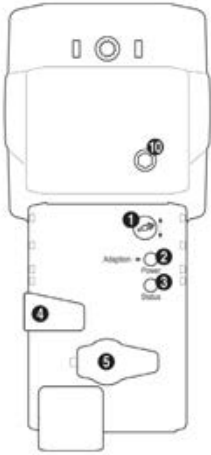

(1) Direction of stroke switch

Switching: Direction of stroke changes

(2) Push-button and LED display green

Off: No power supply or malfunction

Illuminated: In operation

Press button: Triggers stroke adaption, followed by standard mode

(3) LED display yellow

Off: Standard mode

Illuminated: Adaption procedure active

(4) Gear disengagement button

Press button: Gear disengages, motor stops, manual override possible

Release button: Gear engages, standard mode

(5) Service plug

No function

(10) Manual override

Clockwise: Actuator spindle extends

Counterclockwise: Actuator spindle retracts

Dimensions [mm]

Dimensional drawings

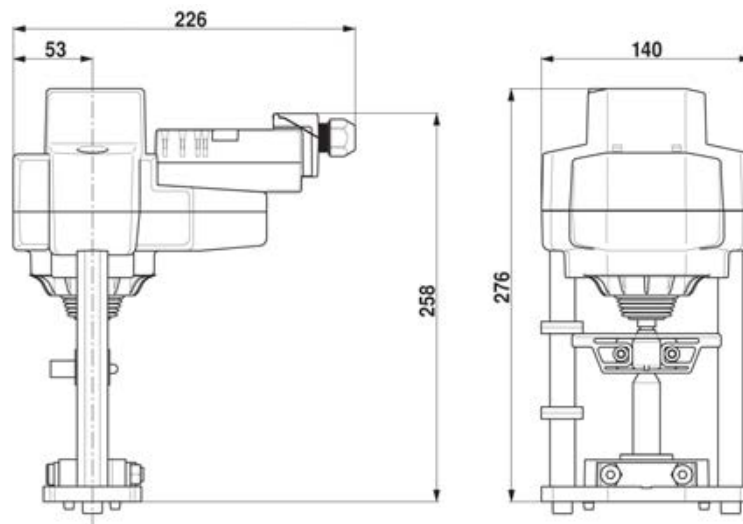

**Communication-capable globe valve actuator
for 2-way and 3-way globe valves**

- Actuating force 2500N
- Nominal voltage AC/DC 24V
- Control modulating DC (0)0.5V...10V, variable
- Nominal stroke 40mm



Technical data

Electrical data	Nominal voltage	AC/DC 24V
	Nominal voltage frequency	50/60Hz
	Nominal voltage range	AC 19.2...28.8V / DC 21.6...28.8V
	Power consumption in operation	4W
	Power consumption in rest position	1.5W
	Power consumption for wire sizing	6VA
	Connection supply / control	Terminals 4mm ² and cable 1m, 4 x 0.75mm ²
	Parallel operation	Yes
Functional data	Actuating force	2500N
	Positioning signal Y	DC 0...10V
	Positioning signal Y note	Input impedance 100kΩ
	Operating range Y	DC 0.5...10V
	Operating range Y variable	Start point DC 0.5...30V
		End point DC 2.5...32V
	Position feedback U	DC 0.5...10V
	Position feedback U note	max. 0.5mA
	Position feedback U variable	Start point DC 0.5...8V
		End point DC 2.5...10V
	Position accuracy	5% absolute
	Manual override	Gear disengagement with push-button, can be locked
	Nominal stroke	40mm
	Actuating time	150s/40mm
	Override control MAX (maximum position)	100%
	Override control MIN (minimum position)	0%
	Override control ZS (intermediate position, only AC)	50%
	Override control ZS variable	ZS = MIN...MAX
	Sound power level motor max.	55dB(A)
	Sound power level motor note	55dB(A) @ 90s running time
Position indication	Mechanical 5...40mm stroke	
Safety	Protection class IEC/EN	III Safety extra-low voltage
	Degree of protection IEC/EN	IP54
	EMC	CE in accordance with 2004/108/EC
	Certification IEC/EN	Certified to: IEC/EN 60730-1 and IEC/EN 60730-2-14
	Mode of operation	Type 1
	Rated impulse voltage supply / control	0.8kV
	Control pollution degree	3
	Ambient temperature	0°C...50°C
	Non-operating temperature	-40°C...80°C
	Ambient humidity	95% r.h., non-condensing
Maintenance	Maintenance-free	
Weight	Weight approx.	4.32kg

Safety notes



- This actuator has been designed for application in stationary heating, ventilation and air-conditioning systems and is not allowed to be used outside the specified field of application, especially in aircraft or in any other airborne means of transport.
- Only authorised specialists may carry out installation. All applicable legal or institutional installation regulations must be complied with during installation.
- The switch for changing the direction of motion/the closing point may be adjusted only by authorised personnel. The direction of stroke is critical, particularly in connection with frost protection circuits.
- The device may only be opened at the manufacturer's site. It does not contain any parts that can be replaced or repaired by the user.
- The device contains electrical and electronic components and is not allowed to be disposed of as household refuse. All locally valid regulations and requirements must be observed.

Product features

Principle of operation	The actuator is connected with a standard modulating signal of DC 0...10V and travels to the position defined by the positioning signal. The measuring voltage U serves for the electrical display of the actuator position 0...100% and as slave control signal for other actuators.
Adjustable-parameter actuators	The factory settings cover the most common applications. Input and output signals and other parameters can be altered with the PC-Tool MFT-P or with the service tool ZTH-GEN.
Direct mounting	Simple direct mounting on the globe valve by means of form-fit hollow clamping jaws. The actuator can be rotated through 360° on the valve neck.
Manual override	Manual override with push-button possible - temporary, permanently. The gear is disengaged and the actuator decoupled for as long as the button is pressed / latched. The stroke can be adjusted by using a hexagon socket screw key (5mm), which is inserted into the top of the actuator. The stroke spindle extends when the key is rotated clockwise.
High functional reliability	The actuator is overload protected, requires no limit switches and automatically stops when the end stop is reached.
Combination valve/actuator	Refer to the valve documentation for suitable valves, their permitted medium temperatures and closing pressures.
Position indication	The stroke is indicated mechanically on the bracket with tabs. The stroke range adjusts itself automatically during operation.
Home position	Setting ex-works: Actuator spindle is retracted. When valve-actuator combinations are shipped, the direction of motion is set in accordance with the closing point of the valve.
Direction of stroke switch	When actuated, the direction of stroke switch changes the running direction in normal operation.
Adaption of stroke range	The first time the supply voltage is switched on, i.e. at the time of commissioning, the actuator carries out a stroke adaption, which is when the operating range and position feedback adjust themselves to the mechanical stroke. Manual triggering of the adaption can be carried out by pressing the "Adaption" button or with the PC-Tool. The actuator then moves into the position defined by the positioning signal.

Accessories

	Description	Type
Electrical accessories	Auxiliary switch add-on, 2 x SPDT	S2A-H
Service tools	Manual parameterising device, for MF/MP/Modbus/LonWorks actuators and VAV-Control	ZTH-GEN
	Belimo PC-Tool, software for adjustments and diagnostics	MFT-P

Electrical installation



Notes • Connection via safety isolating transformer.
 • Parallel connection of other actuators possible.
 • Direction of stroke switch factory setting: Actuator spindle retracted.

Wiring diagrams

AC/DC 24V, modulating

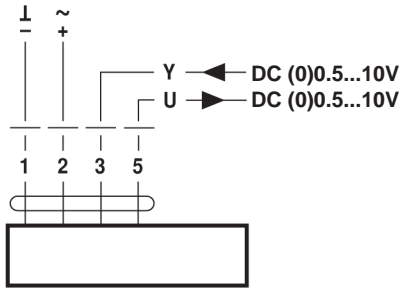

Operation on the MP-Bus

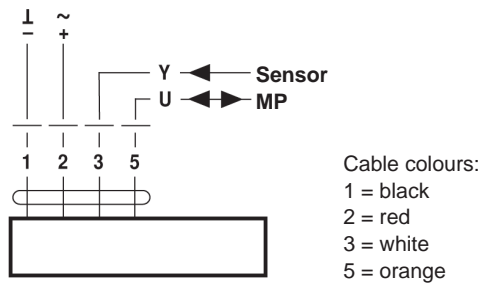

Functions

Functions with basic values

Override control with AC 24V with relay contacts

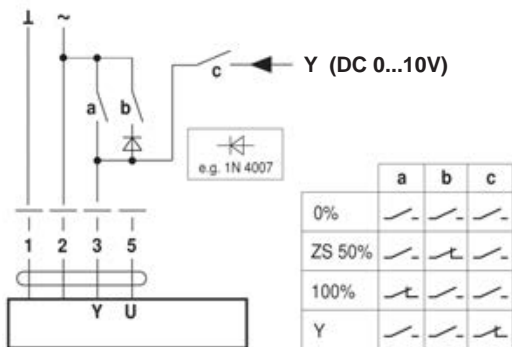

Override control with AC 24V with rotary switch

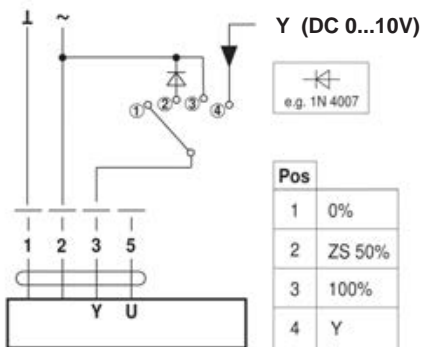

Remote control 0...100%

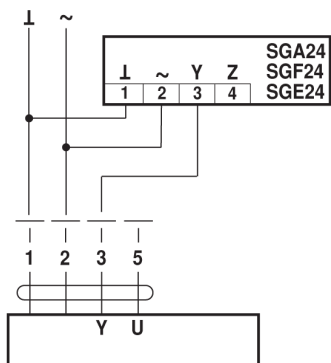

Follow-up control (position-dependent)

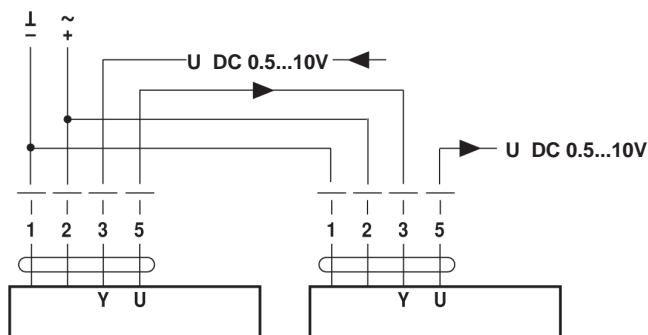

Functions

Control with 4...20mA via external resistor

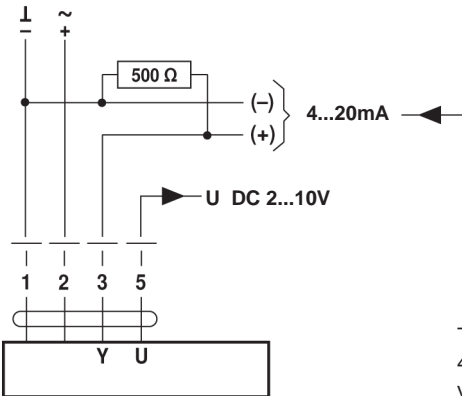

The 500Ω resistor converts the 4...20mA current signal to a voltage signal DC 2...10V

Functions for actuators with specific parameters

Override control and limiting with AC 24V with relay contacts

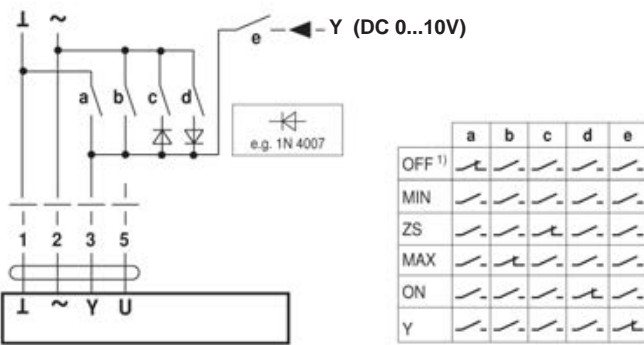

Override control and limiting with AC 24V with rotary switch

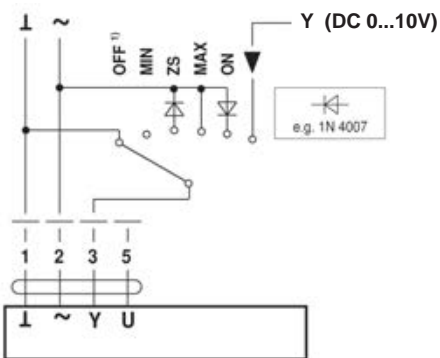

1) Caution: This function is guaranteed only if the start point of the operating range is defined as min. 0.6V.

Functions

AC 24V, 3-point

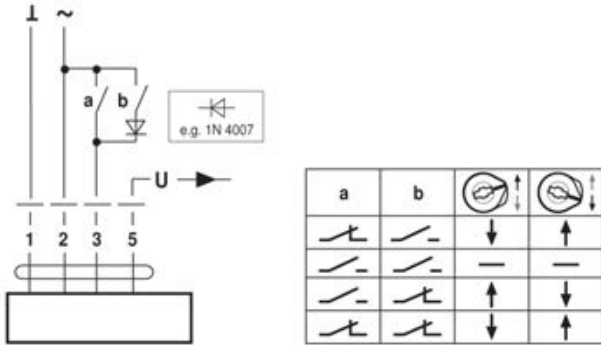

Functions when operated on MP-Bus

Connection on the MP-Bus

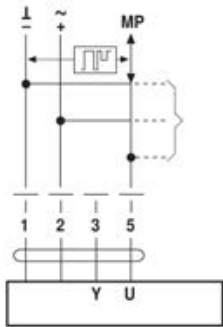

- Supply and communication in one and the same 3-wire cable
- no shielding or twisting required
 - no terminating resistor required

Power topology

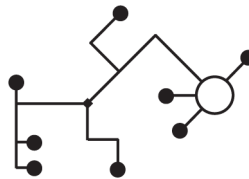

There are no restrictions for the network topology (star, ring, tree or mixed forms are permitted).

Connection of active sensors

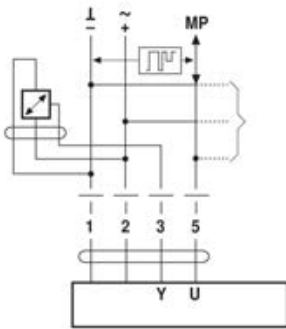

- Supply AC/DC 24A
- Output signal DC 0...10V (max. DC 0...32V)
- Resolution 30mV

Connection of external switching contact

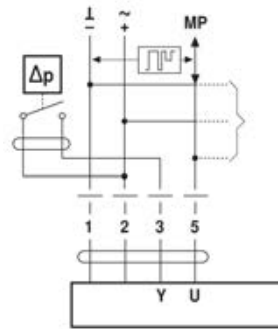

- Switching current 16mA @ 24V
- Start point of the operating range must be parameterised on the MP actuator as $\geq 0.6V$

Connection of passive sensors

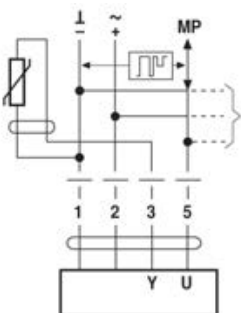

Ni1000	-28 ... +98 °C	850 ... 1600 Ω^2
PT1000	-35 ... +155 °C	850 ... 1600 Ω^2
NTC	-10 ... +160 °C ¹⁾	200 Ω ... 50 k Ω^2

1) Depending on the type
2) Resolution 1 Ohm

Indicators and operating controls

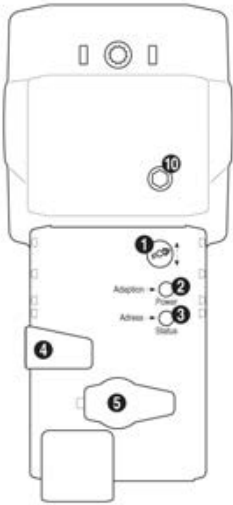

(1) Direction of stroke switch

Switching: Direction of stroke changes

(2) Push-button and LED display green

Off: No power supply or malfunction

Illuminated in green: In operation

Press button: Triggers stroke adaption, followed by standard mode

(3) Push-button and LED display yellow

Off: Standard mode

Flickering: MP communication active

Illuminated: Adaption procedure active

Blinking: Request for addressing from MP master

Press button: Confirmation of addressing

(4) Gear disengagement button

Press button: Gear disengages, motor stops, manual override possible

Release button: Gear engages, standard mode

(5) Service plug

For connecting the parameterisation and service tools

(10) Manual override

Clockwise: Actuator spindle extends

Counterclockwise: Actuator spindle retracts

LED displays (2, green) and (3, yellow)

green: Off; yellow: Illuminated;

Check the supply connections. The phases may have been switched.

Dimensions [mm]

Dimensional drawings

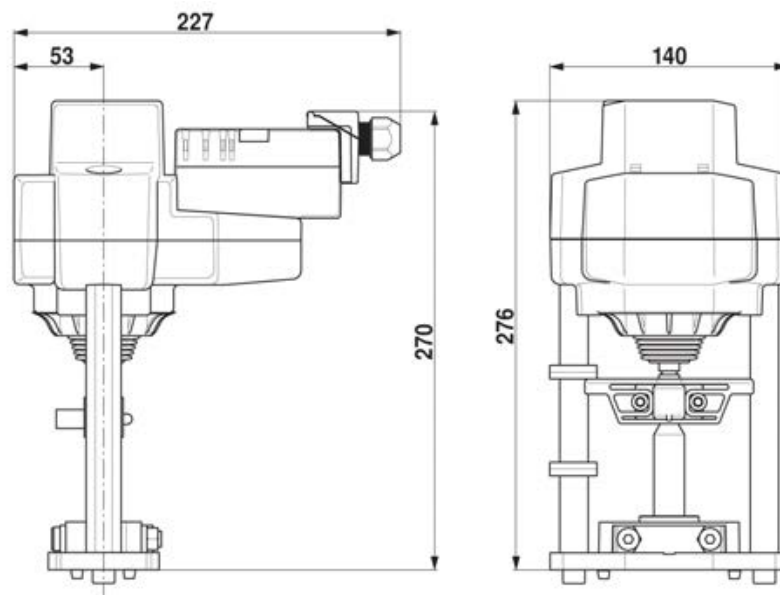

Modulating globe valve actuator for 2-way and 3-way globe valves

- Actuating force 4500N
- Nominal voltage AC/DC 24V
- Control: modulating DC (0)0.5V...10V
- Nominal stroke 40mm

Technical data

Electrical data	Nominal voltage	AC/DC 24V
	Nominal voltage frequency	50/60Hz
	Nominal voltage range	AC 19.2...28.8V / DC 21.6...28.8V
	Power consumption in operation	6W
	Power consumption in rest position	1.5W
	Power consumption for wire sizing	11VA
	Connection supply / control	Cable 1m, 4 x 0.75mm ²
Functional data	Parallel operation	Yes
	Actuating force	4500N
	Positioning signal Y	DC 0...10V
	Positioning signal Y note	Input impedance 100kΩ
	Operating range Y	DC 0.5...10V
	Position feedback U	DC 0.5...10V
	Position feedback U note	max. 0.5mA
	Position accuracy	5% absolute
	Manual override	Gear disengagement with push-button, can be locked
	Nominal stroke	40mm
	Actuating time	150s/40mm
	Sound power level motor max.	55dB(A)
	Safety	Position indication
Protection class IEC/EN		III Safety extra-low voltage
Degree of protection IEC/EN		IP54
EMC		CE in accordance with 2004/108/EC
Certification IEC/EN		Certified to: IEC/EN 60730-1 and IEC/EN 60730-2-14
Mode of operation		Type 1
Rated impulse voltage supply / control		0.8kV
Weight	Control pollution degree	3
	Ambient temperature	0°C...50°C
	Non-operating temperature	-40°C...80°C
	Ambient humidity	95% r.h., non-condensing
	Maintenance	Maintenance-free
	Weight approx.	4.35kg

Safety notes

- This actuator has been designed for application in stationary heating, ventilation and air-conditioning systems and is not allowed to be used outside the specified field of application, especially in aircraft or in any other airborne means of transport.
- Only authorised specialists may carry out installation. All applicable legal or institutional installation regulations must be complied with during installation.
- The switch for changing the direction of motion/the closing point may be adjusted only by authorised personnel. The direction of stroke is critical, particularly in connection with frost protection circuits.
- The device may only be opened at the manufacturer's site. It does not contain any parts that can be replaced or repaired by the user.

Safety notes

- The cable must not be removed from the device.
- The device contains electrical and electronic components and is not allowed to be disposed of as household refuse. All locally valid regulations and requirements must be observed.

Product features

Principle of operation	The actuator is connected with a standard modulating signal of DC 0...10V and travels to the position defined by the positioning signal. The measuring voltage U serves for the electrical display of the actuator position 0...100% and as slave control signal for other actuators.
Direct mounting	Simple direct mounting on the globe valve by means of form-fit hollow clamping jaws. The actuator can be rotated through 360° on the valve neck.
Manual override	Manual override with push-button possible - temporary, permanently. The gear is disengaged and the actuator decoupled for as long as the button is pressed / latched. The stroke can be adjusted by using a hexagon socket screw key (5mm), which is inserted into the top of the actuator. The stroke spindle extends when the key is rotated clockwise.
High functional reliability	The actuator is overload protected, requires no limit switches and automatically stops when the end stop is reached.
Combination valve/actuator	Refer to the valve documentation for suitable valves, their permitted medium temperatures and closing pressures. The stroke is indicated mechanically on the bracket with tabs. The stroke range adjusts itself automatically during operation.
Home position	Setting ex-works: Actuator spindle is retracted. When valve-actuator combinations are shipped, the direction of motion is set in accordance with the closing point of the valve.
Direction of stroke switch	When actuated, the direction of stroke switch changes the running direction in normal operation.
Adaption of stroke range	The first time the supply voltage is switched on, i.e. at the time of commissioning, the actuator carries out a stroke adaption, which is when the operating range and position feedback adjust themselves to the mechanical stroke. Manual triggering of the adaption can be carried out by pressing the "Adaption" button. The actuator then moves into the position defined by the positioning signal.

Accessories

	Description	Type
Electrical accessories	Auxiliary switch add-on, 2 x SPDT	S2A-H

Electrical installation



- Notes
- Connection via safety isolating transformer.
 - Parallel connection of other actuators possible
 - Direction of stroke switch factory setting: Actuator spindle retracted.

Wiring diagrams

AC/DC 24V, modulating

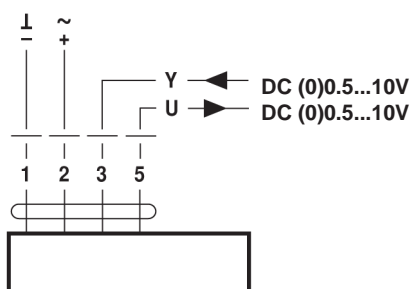

Indicators and operating controls

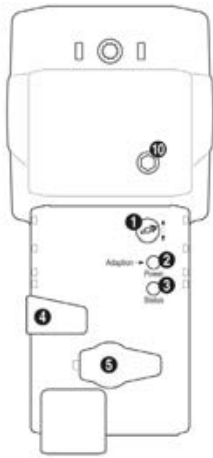

- (1) Direction of stroke switch**
Switching: Direction of stroke changes
- (2) Push-button and LED display green**
Off: No power supply or malfunction
Illuminated: In operation
Press button: Triggers stroke adaption, followed by standard mode
- (3) LED display yellow**
Off: Standard mode
Illuminated: Adaption procedure active
- (4) Gear disengagement button**
Press button: Gear disengages, motor stops, manual override possible
Release button: Gear engages, standard mode
- (5) Service plug**
No function
- (10) Manual override**
Clockwise: Actuator spindle extends
Counterclockwise: Actuator spindle retracts

Dimensions [mm]

Dimensional drawings

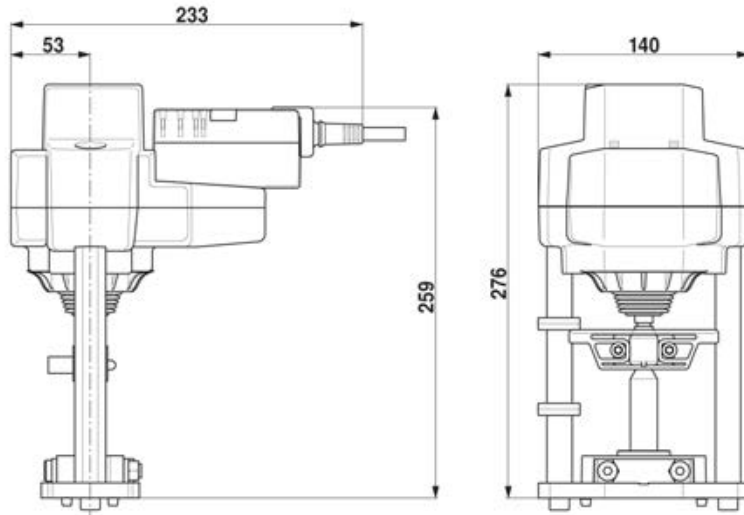

Parameterisable globe valve actuator for 2-way and 3-way globe valves

- Actuating force 4500N
- Nominal voltage AC/DC 24V
- Control modulating DC (0)0.5V...10V, variable
- Nominal stroke 40mm

Technical data

Electrical data	Nominal voltage	AC/DC 24V
	Nominal voltage frequency	50/60Hz
	Nominal voltage range	AC 19.2...28.8V / DC 21.6...28.8V
	Power consumption in operation	6W
	Power consumption in rest position	1.5W
	Power consumption for wire sizing	11VA
	Connection supply / control	Cable 1m, 4 x 0.75mm ²
	Parallel operation	Yes
Functional data	Actuating force	4500N
	Positioning signal Y	DC 0...10V
	Positioning signal Y note	Input impedance 100kΩ
	Operating range Y	DC 0.5...10V
	Operating range Y variable	Start point DC 0.5...30V End point DC 2.5...32V
	Position feedback U	DC 0.5...10V
	Position feedback U note	max. 0.5mA
	Position feedback U variable	Start point DC 0.5...8V End point DC 2.5...10V
	Position accuracy	5% absolute
	Manual override	Gear disengagement with push-button, can be locked
	Nominal stroke	40mm
	Actuating time	150s/40mm
	Override control MAX (maximum position)	100%
	Override control MIN (minimum position)	0%
	Override control ZS (intermediate position, only AC)	50%
	Override control ZS variable	ZS = MIN...MAX
	Sound power level motor max.	55dB(A)
Sound power level motor note	65dB(A) @ 90s running time	
Position indication	Mechanical 5...40mm stroke	
Safety	Protection class IEC/EN	III Safety extra-low voltage
	Degree of protection IEC/EN	IP54
	EMC	CE in accordance with 2004/108/EC
	Certification IEC/EN	Certified to: IEC/EN 60730-1 and IEC/EN 60730-2-14
	Mode of operation	Type 1
	Rated impulse voltage supply / control	0.8kV
	Control pollution degree	3
	Ambient temperature	0°C...50°C
	Non-operating temperature	-40°C...80°C
	Ambient humidity	95% r.h., non-condensing
Weight	Maintenance	Maintenance-free
	Weight approx.	4.35kg

Safety notes



- This actuator has been designed for application in stationary heating, ventilation and air-conditioning systems and is not allowed to be used outside the specified field of application, especially in aircraft or in any other airborne means of transport.
- Only authorised specialists may carry out installation. All applicable legal or institutional installation regulations must be complied with during installation.
- The switch for changing the direction of motion/the closing point may be adjusted only by authorised personnel. The direction of stroke is critical, particularly in connection with frost protection circuits.
- The device may only be opened at the manufacturer's site. It does not contain any parts that can be replaced or repaired by the user.
- The cable must not be removed from the device.
- The device contains electrical and electronic components and is not allowed to be disposed of as household refuse. All locally valid regulations and requirements must be observed.

Product features

Principle of operation	The actuator is connected with a standard modulating signal of DC 0...10V and travels to the position defined by the positioning signal. The measuring voltage U serves for the electrical display of the actuator position 0...100% and as slave control signal for other actuators.
Adjustable-parameter actuators	The factory settings cover the most common applications. Input and output signals and other parameters can be altered with the PC-Tool MFT-P or with the service tool ZTH-GEN.
Direct mounting	Simple direct mounting on the globe valve by means of form-fit hollow clamping jaws. The actuator can be rotated through 360° on the valve neck.
Manual override	Manual override with push-button possible - temporary, permanently. The gear is disengaged and the actuator decoupled for as long as the button is pressed / latched. The stroke can be adjusted by using a hexagon socket screw key (5mm), which is inserted into the top of the actuator. The stroke spindle extends when the key is rotated clockwise.
High functional reliability	The actuator is overload protected, requires no limit switches and automatically stops when the end stop is reached.
Combination valve/actuator	Refer to the valve documentation for suitable valves, their permitted medium temperatures and closing pressures.
Position indication	The stroke is indicated mechanically on the bracket with tabs. The stroke range adjusts itself automatically during operation.
Home position	Setting ex-works: Actuator spindle is retracted. When valve-actuator combinations are shipped, the direction of motion is set in accordance with the closing point of the valve.
Direction of stroke switch	When actuated, the direction of stroke switch changes the running direction in normal operation.
Adaption of stroke range	The first time the supply voltage is switched on, i.e. at the time of commissioning, the actuator carries out a stroke adaption, which is when the operating range and position feedback adjust themselves to the mechanical stroke. Manual triggering of the adaption can be carried out by pressing the "Adaption" button or with the PC-Tool. The actuator then moves into the position defined by the positioning signal.

Accessories

	Description	Type
Electrical accessories	Auxiliary switch add-on, 2 x SPDT	S2A-H
Service tools	Manual parameterising device, for MF/MP/Modbus/LonWorks actuators and VAV-Control	ZTH-GEN
	Belimo PC-Tool, software for adjustments and diagnostics	MFT-P

Electrical installation



- Notes
- Connection via safety isolating transformer.
 - Parallel connection of other actuators possible.
 - Direction of stroke switch factory setting: Actuator spindle retracted.

Wiring diagrams

AC/DC 24V, modulating

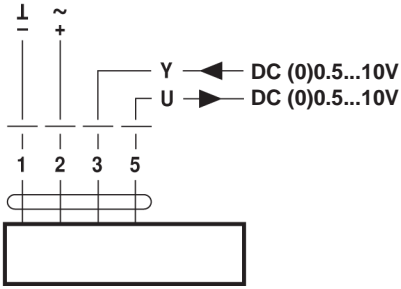

Cable colours:
 1 = black
 2 = red
 3 = white
 5 = orange

Functions

Functions with basic values

Override control with AC 24V with relay contacts

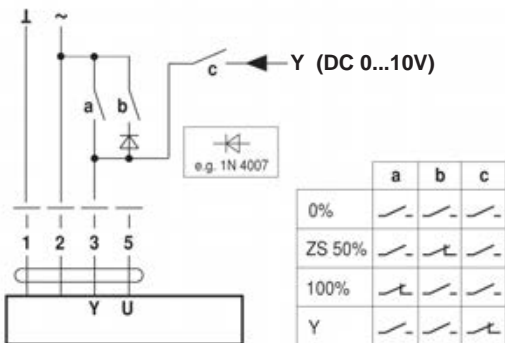

Override control with AC 24V with rotary switch

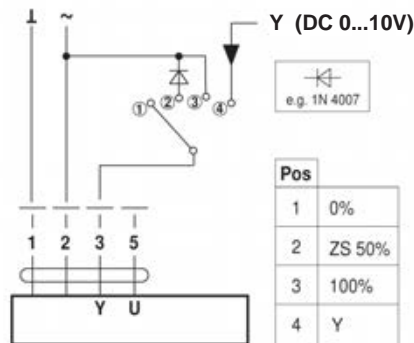

Remote control 0...100%

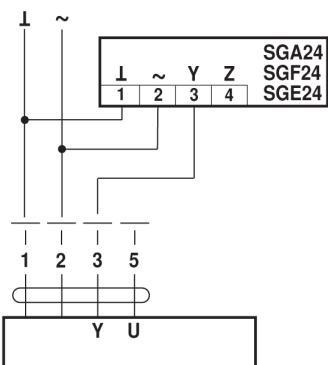

Follow-up control (position-dependent)

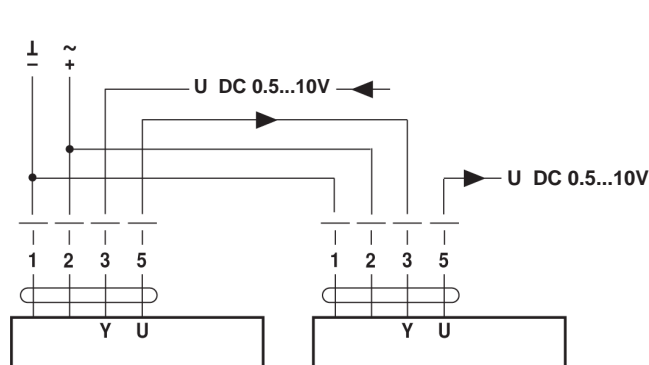

Functions

Position Indication

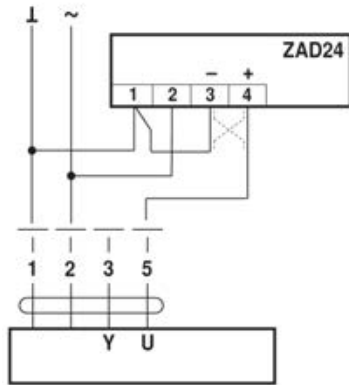

Control with 4...20mA via external resistance

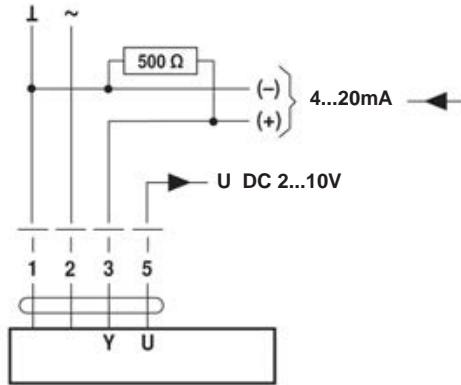

Functions for actuators with specific parameters

Override control and limiting with AC 24V with relay contacts

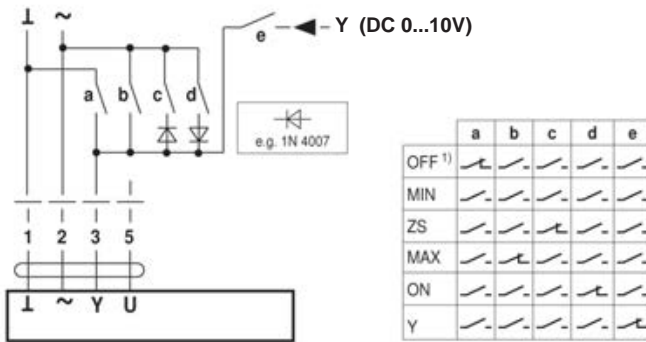

The 500 Ohm resistor converts the 4...20mA current signal to a voltage signal DC 2...10V

Override control and limiting with AC 24V with rotary switch

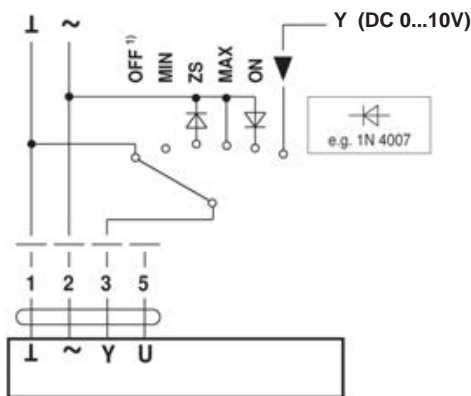

1) Caution: This function is guaranteed only if the start point of the operating range is defined as min. 0.6V.

Functions

AC 24V, 3-point

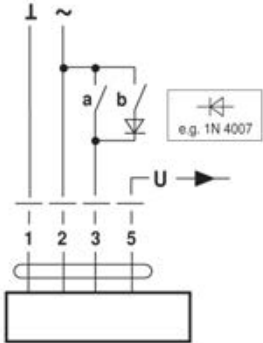

a	b		

Indicators and operating controls

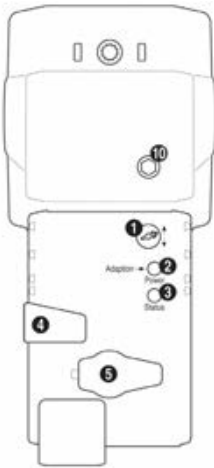

(1) Direction of stroke switch

Switching: Direction of stroke changes

(2) Push-button and LED display green

Off: No power supply or malfunction

Illuminated in green: In operation

Press button: Triggers stroke adaption, followed by standard mode

(3) LED display yellow

Off: Standard mode

Illuminated: Adaption procedure active

(4) Gear disengagement button

Press button: Gear disengages, motor stops, manual override possible

Release button: Gear engages, standard mode

(5) Service plug

For connecting the parameterisation and service tools

(10) Manual override

Clockwise: Actuator spindle extends

Counterclockwise: Actuator spindle retracts

Dimensions [mm]

Dimensional drawings

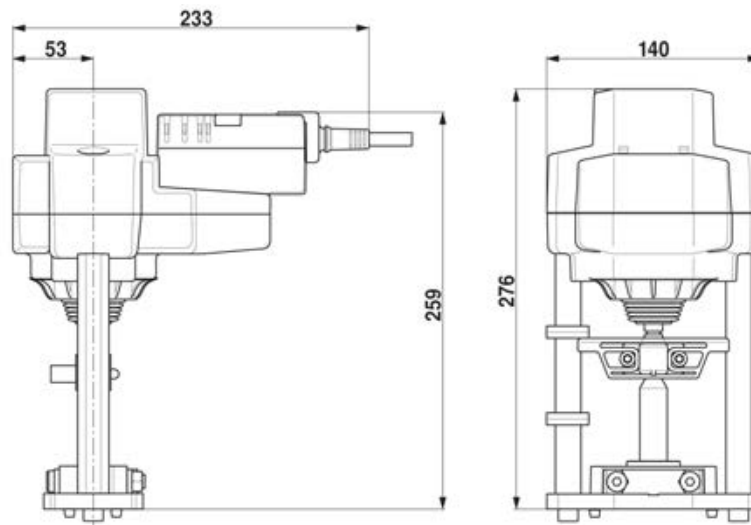

**Globe valve actuator with emergency control function
for 2-way and 3-way globe valves**

- Actuating force 1000N
- Nominal voltage AC/DC 24V
- 3-point control
- Nominal stroke 20mm
- Design life SuperCaps 15 years

Technical data

Electrical data	Nominal voltage	AC/DC 24V	
	Nominal voltage frequency	50/60Hz	
	Nominal voltage range	AC 19.2...28.8V / DC 21.6...28.8V	
	Power consumption in operation	2.5W	
	Power consumption in rest position	1.5W	
	Power consumption for wire sizing	6VA	
	Connection supply / control	Terminals 4mm ² and cable 1m, 4 x 0.75mm ²	
Functional data	Parallel operation	Yes	
	Actuating force	1000N	
	Adjusting emergency setting position	Actuator spindle retracted / extended, adjustable (POP rotary knob)	
	Manual override	Gear disengagement with push-button	
	Nominal stroke	20mm	
	Actuating time	150s/20mm	
	Actuating time emergency control function	35s/20mm	
	Sound power level motor max.	55dB(A)	
	Sound power level emergency setting position max.	60dB(A)	
	Position indication	Mechanical 5...20mm stroke	
	Safety	Protection class IEC/EN	III Safety extra-low voltage
		Degree of protection IEC/EN	IP54
		EMC	CE in accordance with 2004/108/EC
Certification IEC/EN		Certified to: IEC/EN 60730-1 and IEC/EN 60730-2-14	
Mode of operation		Type 1.AA	
Rated impulse voltage supply / control		0.8kV	
Control pollution degree		3	
Ambient temperature		0°C...50°C	
Non-operating temperature		-40°C...80°C	
Ambient humidity		95% r.h., non-condensing	
Weight	Maintenance	Maintenance-free	
	Weight approx.	1.61kg	

Safety notes

- This actuator has been designed for application in stationary heating, ventilation and air-conditioning systems and is not allowed to be used outside the specified field of application, especially in aircraft or in any other airborne means of transport.
- Only authorised specialists may carry out installation. All applicable legal or institutional installation regulations must be complied with during installation.
- The switch for changing the direction of motion/the closing point may be adjusted only by authorised personnel. The direction of stroke is critical, particularly in connection with frost protection circuits.
- The device may only be opened at the manufacturer's site. It does not contain any parts that can be replaced or repaired by the user.
- The device contains electrical and electronic components and is not allowed to be disposed of as household refuse. All locally valid regulations and requirements must be observed.

Product features

Principle of operation

The actuator moves the valve to the desired operating position at the same time as the integrated capacitors are loaded.

Interrupting the supply voltage causes the valve to be moved to the selected emergency setting position (POP) by means of stored electrical energy.

Pre-charging time (start up)

The capacitor actuators require a pre-charging time. This time is used for charging the capacitors up to a usable voltage level. This ensures that, in the event of an electricity interruption, the actuator can move at any time from its current position into the preset emergency setting position (POP).

The duration of the pre-charging time depends mainly on how long the power was interrupted.

Typical pre-charging time

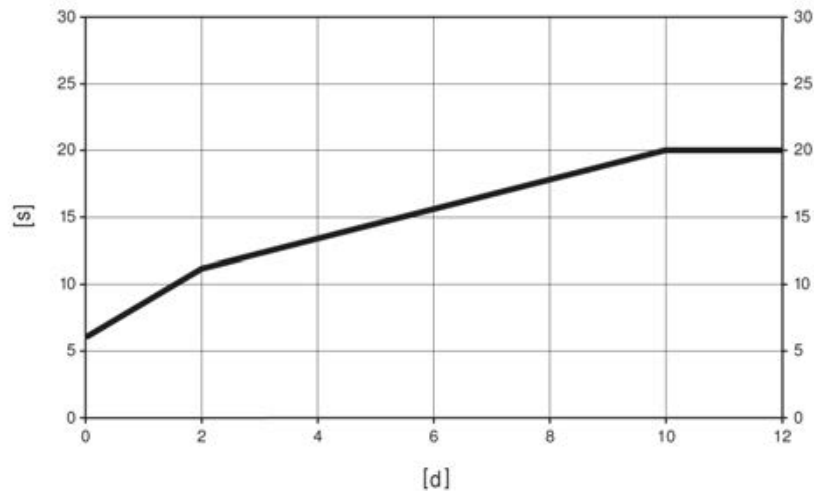

[d] = Electricity interruption in days
 [s] = Pre-charging time in seconds
 PF[s] = Bridging time

	[d]				
	0	1	2	7	≥10
[s]	6	9	11	16	20

Delivery condition (capacitors)

The actuator is completely discharged after delivery from the factory, which is why the actuator requires approximately 20s pre-charging time before initial commissioning in order to bring the capacitors up to the required voltage level.

Direct mounting

Simple direct mounting on the globe valve by means of form-fit hollow clamping jaws. The actuator can be rotated through 360° on the valve neck.

Manual override

Manual override with push-button possible - temporary. The gear is disengaged and the actuator decoupled for as long as the button is pressed.

The stroke can be adjusted by using a hexagon socket screw key (4mm), which is inserted into the top of the actuator. The stroke spindle extends when the key is rotated clockwise.

High functional reliability

The actuator is overload protected, requires no limit switches and automatically stops when the end stop is reached.

Combination valve/actuator

Refer to the valve documentation for suitable valves, their permitted medium temperatures and closing pressures.

Position indication

The stroke is indicated mechanically on the bracket with tabs. The stroke range adjusts itself automatically during operation.

Direction of stroke switch

When actuated, the direction of stroke switch changes the running direction in normal operation. The direction of stroke switch has no influence on the emergency setting position (POP) which has been set.

Rotary knob emergency setting position

The "Emergency setting position" rotary knob can be used to adjust the desired emergency setting position (POP). The POP range is in reference to the maximum height of stroke of the actuator.

In the event of an electricity interruption, the actuator will move into the selected emergency setting position, taking into account the bridging time (PF) of 2s which was set ex-works.

Accessories

Electrical accessories

Description

Type

Auxiliary switch add-on, 2 x SPDT

S2A-H

Electrical installation



- Notes
- Connection via safety isolating transformer.
 - Parallel connection of other actuators possible
 - Direction of stroke switch factory setting: Actuator spindle retracted.

Wiring diagrams

AC 24V, 3-point

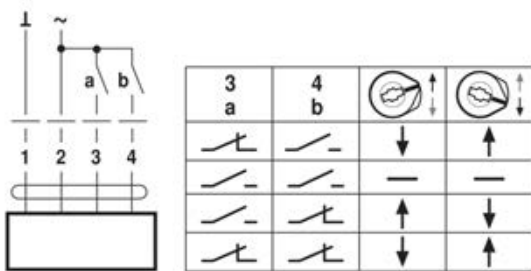

Cable colours:

- 1 = black
- 2 = red
- 3 = white
- 4 = white

Indicators and operating controls

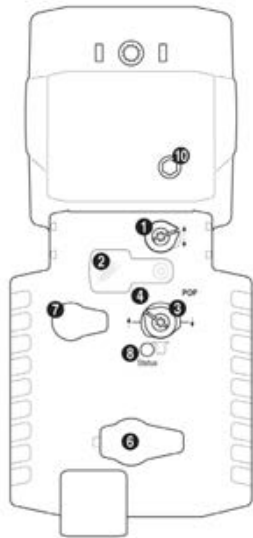

- (1) Direction of stroke switch**
Switching: Direction of stroke changes
- (2) Cover, POP button**
- (3) POP button**
- (4) Scale for manual adjustment**
- (6) No function**
- (7) Gear disengagement button, temporary**
Press button: Gear disengages, motor stops, manual override possible
Release button: Gear engages, standard mode
- (8) LED displays**
Green: Off, Not in operation / Pre-charging time SuperCap / Faulty SuperCap
Green: Illuminated, in operation OK
Green: Blinking, POP function active
- (10) Manual override**
Clockwise: Actuator spindle extends
Counterclockwise: Actuator spindle retracts

Indicators and operating controls

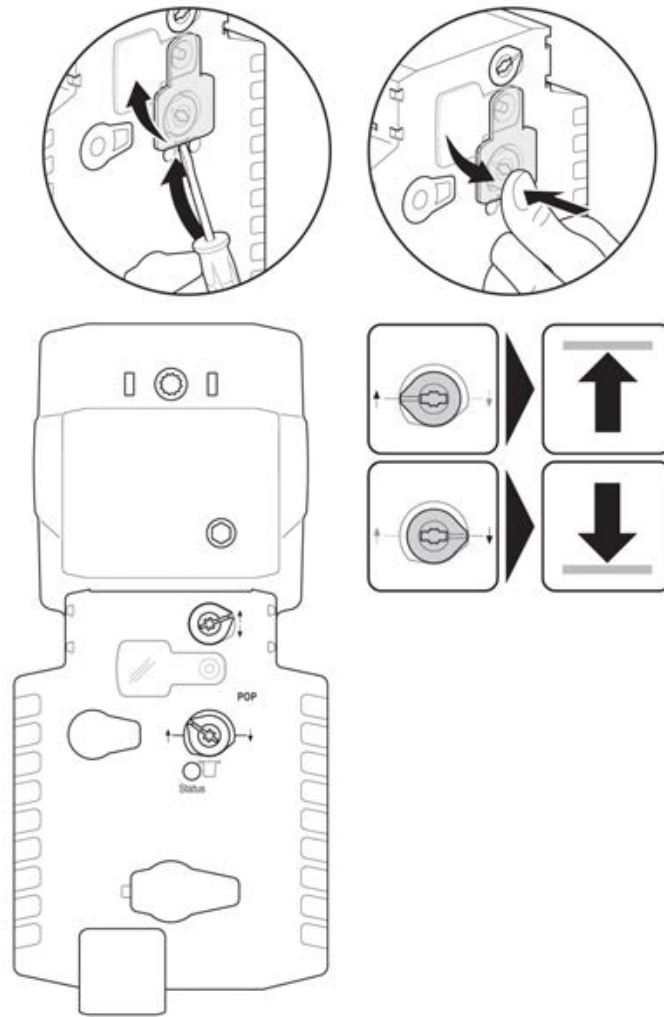

Dimensions [mm]

Dimensional drawings

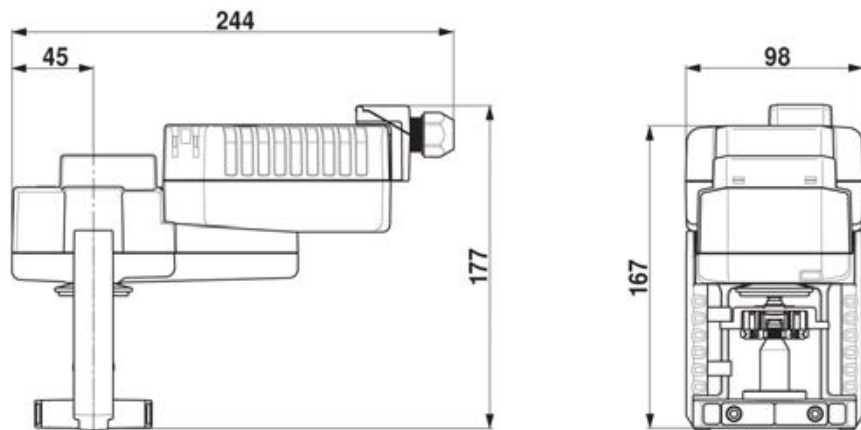

**Globe valve actuator with emergency control function
for 2-way and 3-way globe valves**

- Actuating force 1000N
- Nominal voltage AC 230V
- 3-point control
- Nominal stroke 20mm
- Design life SuperCaps 15 years

Technical data

Electrical data	Nominal voltage	AC 230V	
	Nominal voltage frequency	50/60Hz	
	Nominal voltage range	AC 198...264V	
	Power consumption in operation	2W	
	Power consumption in rest position	1W	
	Power consumption for wire sizing	4.5VA	
	Connection supply / control	Cable 1m, 4 x 0.75mm ²	
Functional data	Parallel operation	Yes	
	Actuating force	1000N	
	Adjusting emergency setting position	Actuator spindle retracted / extended, adjustable (POP rotary knob)	
	Manual override	Gear disengagement with push-button	
	Nominal stroke	20mm	
	Actuating time	150s/20mm	
	Actuating time emergency control function	35s/20mm	
	Sound power level motor max.	56dB(A)	
	Sound power level emergency setting position max.	60dB(A)	
	Position indication	Mechanical 5...20mm stroke	
	Safety	Protection class IEC/EN	II protective insulated
		Degree of protection IEC/EN	IP54
		EMC	CE in accordance with 2004/108/EC
Certification IEC/EN		Certified to: IEC/EN 60730-1 and IEC/EN 60730-2-14	
Mode of operation		Type 1.AA	
Rated impulse voltage supply / control		4kV	
Control pollution degree		3	
Ambient temperature		0°C...50°C	
Non-operating temperature		-40°C...80°C	
Ambient humidity		95% r.h., non-condensing	
Weight	Maintenance	Maintenance-free	
	Weight approx.	1.63kg	

Safety notes

- This actuator has been designed for application in stationary heating, ventilation and air-conditioning systems and is not allowed to be used outside the specified field of application, especially in aircraft or in any other airborne means of transport.
- Only authorised specialists may carry out installation. All applicable legal or institutional installation regulations must be complied with during installation.
- The switch for changing the direction of motion/the closing point may be adjusted only by authorised personnel. The direction of stroke is critical, particularly in connection with frost protection circuits.
- The device may only be opened at the manufacturer's site. It does not contain any parts that can be replaced or repaired by the user.
- The cable must not be removed from the device.
- The device contains electrical and electronic components and is not allowed to be disposed of as household refuse. All locally valid regulations and requirements must be observed.

Product features

Mode of operation

The actuator moves the valve to the desired operating position at the same time as the integrated capacitors are loaded.

Interrupting the supply voltage causes the valve to be moved to the selected emergency setting position (POP) by means of stored electrical energy.

Pre-charging time (start up)

The capacitor actuators require a pre-charging time. This time is used for charging the capacitors up to a usable voltage level. This ensures that, in the event of an electricity interruption, the actuator can move at any time from its current position into the preset emergency setting position (POP).

The duration of the pre-charging time depends mainly on how long the power was interrupted.

Typical pre-charging time

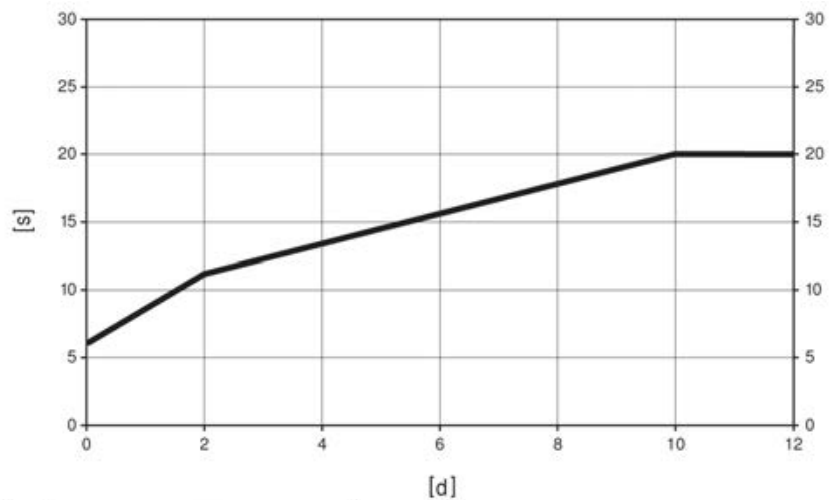

[d] = Electricity interruption in days
 [s] = Pre-charging time in seconds
 PF[s] = Bridging time

	[d]				
	0	1	2	7	≥10
[s]	6	9	11	16	20

Delivery condition (capacitors)

The actuator is completely discharged after delivery from the factory, which is why the actuator requires approximately 20s pre-charging time before initial commissioning in order to bring the capacitors up to the required voltage level.

Direct mounting

Simple direct mounting on the globe valve by means of form-fit hollow clamping jaws. The actuator can be rotated through 360° on the valve neck.

Manual override

Manual override with push-button possible - temporary. The gear is disengaged and the actuator decoupled for as long as the button is pressed.

The stroke can be adjusted by using a hexagon socket screw key (4mm), which is inserted into the top of the actuator. The stroke spindle extends when the key is rotated clockwise.

High functional reliability

The actuator is overload protected, requires no limit switches and automatically stops when the end stop is reached.

Combination valve/actuator

Refer to the valve documentation for suitable valves, their permitted medium temperatures and closing pressures.

Position indication

The stroke is indicated mechanically on the bracket with tabs. The stroke range adjusts itself automatically during operation.

Home position

Setting ex-works: Actuator spindle is retracted.

When valve-actuator combinations are shipped, the direction of motion is set in accordance with the closing point of the valve.

Direction of stroke switch

When actuated, the direction of stroke switch changes the running direction in normal operation. The direction of stroke switch has no influence on the emergency setting position (POP) which has been set.

Rotary knob emergency setting position

The "Emergency setting position" rotary knob can be used to adjust the desired emergency setting position (POP). The POP range is in reference to the maximum height of stroke of the actuator.

In the event of an electricity interruption, the actuator will move into the selected emergency setting position, taking into account the bridging time (PF) of 2s which was set ex-works.

Accessories

Electrical accessories

Description

Type

Auxiliary switch add-on, 2 x SPDT

S2A-H

Electrical installation



- Notes
- Parallel connection of other actuators possible
 - Direction of stroke switch factory setting: Actuator spindle retracted.

Wiring diagrams

AC 230V, 3-point

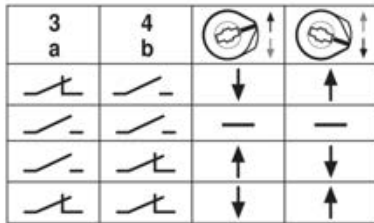
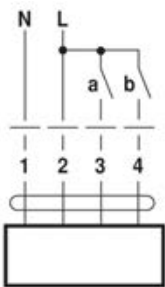

Cable colours:
 1 = blue
 2 = brown
 3 = white
 4 = white

Indicators and operating controls

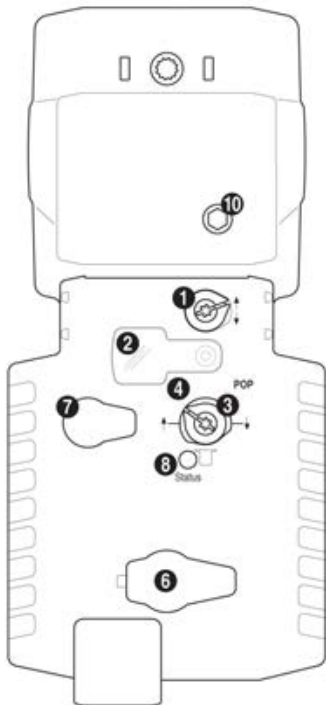

- (1) Direction of stroke switch**
Switching: Direction of stroke changes
- (2) Cover, POP button**
- (3) POP button**
- (4) Scale for manual adjustment**
- (6) No function**
- (7) Gear disengagement button, temporary**
Press button: Gear disengages, motor stops, manual override possible
Release button: Gear engages, standard mode
- (8) LED displays**
Green: Off, Not in operation / Pre-charging time SuperCap / Faulty SuperCap
Green: Illuminated, in operation OK
Green: Blinking, POP function active
- (10) Manual override**
Clockwise: Actuator spindle extends
Counterclockwise: Actuator spindle retracts

Indicators and operating controls

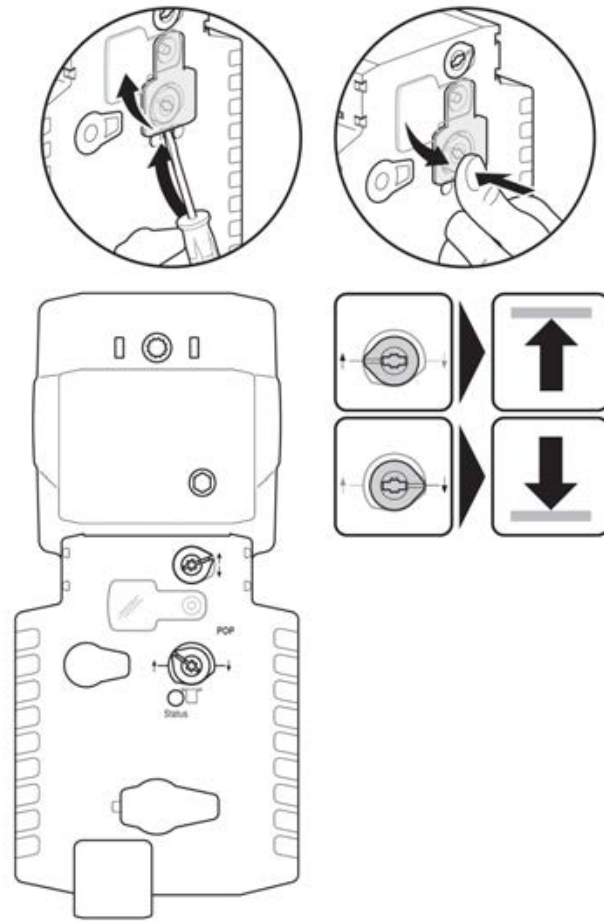

Dimensions [mm]

Dimensional drawings

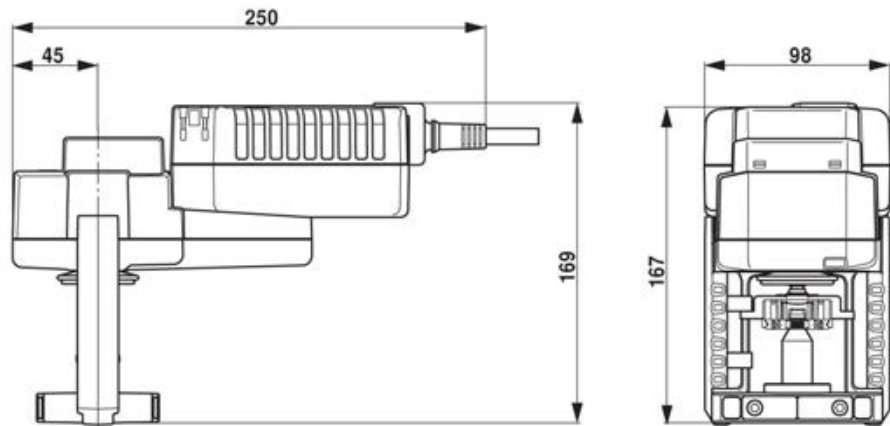

Communication-capable globe valve actuator with emergency control function for 2-way and 3-way globe valves

- Actuating force 1000N
- Nominal voltage AC/DC 24V
- Control modulating DC (0)0.5V...10V, variable
- Nominal stroke 20mm
- Design life SuperCaps 15 years



Technical data

Electrical data	Nominal voltage	AC/DC 24V
	Nominal voltage frequency	50/60Hz
	Nominal voltage range	AC 19.2...28.8V / DC 21.6...28.8V
	Power consumption in operation	2.5W
	Power consumption in rest position	1.5W
	Power consumption for wire sizing	6VA
	Connection supply / control	Terminals 4mm ² and cable 1m, 4 x 0.75mm ²
Functional data	Parallel operation	Yes
	Actuating force	1000N
	Positioning signal Y	DC 0...10V
	Positioning signal Y note	Input impedance 100kΩ
	Operating range Y	DC 0.5...10V
	Operating range Y variable	Start point DC 0.5...30V
		End point DC 2.5...32V
	Position feedback U	DC 0.5...10V
	Position feedback U note	max. 0.5mA
	Position feedback U variable	Start point DC 0.5...8V
		End point DC 2.5...10V
	Adjusting emergency setting position	Actuator spindle 0...100%, adjustable (POP rotary knob)
	Bridging time (PF) variable	1...10s
	Position accuracy	5% absolute
	Manual override	Gear disengagement with push-button
	Nominal stroke	20mm
	Actuating time	150s/20mm
	Actuating time emergency control function	35s/20mm
	Override control MAX (maximum position)	100%
	Override control MIN (minimum position)	0%
	Override control ZS (intermediate position, only AC)	50%
	Override control ZS variable	ZS = MIN...MAX
	Sound power level motor max.	55dB(A)
Sound power level motor note	55dB(A) @ 90s running time	
Sound power level emergency setting position max.	60dB(A)	
Safety	Position indication	Mechanical 5...20mm stroke
	Protection class IEC/EN	III Safety extra-low voltage
	Degree of protection IEC/EN	IP54
	EMC	CE in accordance with 2004/108/EC
	Certification IEC/EN	Certified to: IEC/EN 60730-1 and IEC/EN 60730-2-14
	Mode of operation	Type 1.AA
	Rated impulse voltage supply / control	0.8kV
	Control pollution degree	3

Technical data

Safety	Ambient temperature	0°C...50°C
	Non-operating temperature	-40°C...80°C
	Ambient humidity	95% r.h., non-condensing
	Maintenance	Maintenance-free
Weight	Weight approx.	1.61kg

Safety notes



- This actuator has been designed for application in stationary heating, ventilation and air-conditioning systems and is not allowed to be used outside the specified field of application, especially in aircraft or in any other airborne means of transport.
- Only authorised specialists may carry out installation. All applicable legal or institutional installation regulations must be complied with during installation.
- The switch for changing the direction of motion/the closing point may be adjusted only by authorised personnel. The direction of stroke is critical, particularly in connection with frost protection circuits.
- The device may only be opened at the manufacturer's site. It does not contain any parts that can be replaced or repaired by the user.
- The device contains electrical and electronic components and is not allowed to be disposed of as household refuse. All locally valid regulations and requirements must be observed.

Product features

Principle of operation

The actuator is connected with a standard modulating signal of DC 0...10V and travels to the position defined by the positioning signal at the same time the integrated capacitors are being charged.

Interrupting the supply voltage causes the valve to be moved to the selected emergency setting position (POP) by means of stored electrical energy.

Pre-charging time (start up)

The capacitor actuators require a pre-charging time. This time is used for charging the capacitors up to a usable voltage level. This ensures that, in the event of an electricity interruption, the actuator can move at any time from its current position into the preset emergency setting position (POP).

The duration of the pre-charging time depends mainly on the following factors:

- Duration of the voltage interruption
- PF delay time (bridging time)

Typical pre-charging time

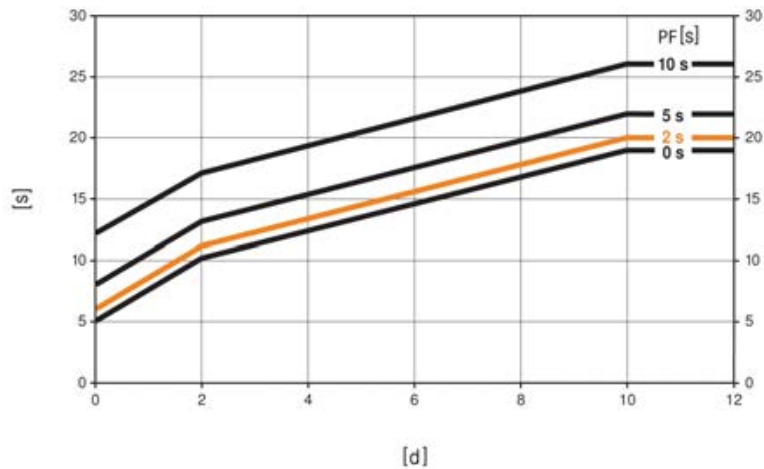

PF [s]	[d]				
	0	1	2	7	≥10
0	5	8	10	15	19
2	6	9	11	16	20
5	8	11	13	18	22
10	12	15	17	22	26
[s]					

[d] = Electricity interruption in days

[s] = Pre-charging time in seconds

PF[s] = Bridging time

Calculation example: In the event of an electricity interruption of 3 days and a set bridging time (PF) of 5s, the actuator requires a pre-charging time of 14s (see graphic) after the voltage has been reconnected.

Product features

Delivery condition (capacitors)	The actuator is completely discharged after delivery from the factory, which is why the actuator requires approximately 20s pre-charging time before initial commissioning in order to bring the capacitors up to the required voltage level.
Adjustable-parameter actuators	The factory settings cover the most common applications. Input and output signals and other parameters can be altered with the PC-Tool MFT-P or with the service tool ZTH-GEN.
 Direct mounting	Simple direct mounting on the globe valve by means of form-fit hollow clamping jaws. The actuator can be rotated through 360° on the valve neck.
 Manual override	Manual override with push-button possible - temporary. The gear is disengaged and the actuator decoupled for as long as the button is pressed. The stroke can be adjusted by using a hexagon socket screw key (4mm), which is inserted into the top of the actuator. The stroke spindle extends when the key is rotated clockwise.
High functional reliability	The actuator is overload protected, requires no limit switches and automatically stops when the end stop is reached.
Combination valve/actuator	Refer to the valve documentation for suitable valves, their permitted medium temperatures and closing pressures.
 Position indication	The stroke is indicated mechanically on the bracket with tabs. The stroke range adjusts itself automatically during operation.
 Home position	Setting ex-works: Actuator spindle is retracted. When valve-actuator combinations are shipped, the direction of motion is set in accordance with the closing point of the valve.
Direction of stroke switch	When actuated, the direction of stroke switch changes the running direction in normal operation. The direction of stroke switch has no influence on the emergency setting position (POP) which has been set.
Adaption of stroke range	The first time the supply voltage is switched on, i.e. at the time of commissioning, the actuator carries out a stroke adaption, which is when the operating range and position feedback adjust themselves to the mechanical stroke. Manual triggering of the adaption can be carried out by pressing the "Adaption" button or with the PC-Tool. The actuator then moves into the position defined by the positioning signal.
Rotary knob emergency setting position	The "Emergency setting position" rotary knob can be used to adjust the desired emergency setting position (POP) from 0% to 100% in 10% increments. The rotary knob is in reference to the adapted or programmed height of stroke. In the event of an electricity interruption, the actuator will move into the selected emergency setting position, taking into account the bridging time (PF) of 2s which was set ex-works. Settings: The rotary knob must be set to the "Tool" position for retroactive settings of the emergency setting position with the Belimo service tool MFT-P. Once the rotary knob is set back to the range 0...100%, the manually set value will have positioning authority.
 Bridging time (PF)	Electricity interruptions can be bridged up to a maximum of 10s. In the event of an electricity interruption, the actuator will remain stationary in accordance with the set bridging time. If the electricity interruption is greater than the set bridging time, then the actuator will move into the selected emergency setting position (POP). The bridging time set ex-works is 2s. This can be modified at the site of operations with the use of the Belimo service tool MFT-P. Settings: The rotary knob must not be set to the "Tool" position! Only the values need to be entered for retroactive adjustments of the bridging time with the Belimo service tool MFT-P.

Accessories

	Description	Type
Electrical accessories	Auxiliary switch add-on, 2 x SPDT	S2A-H
Service tools	Manual parameterising device, for MF/MP/Modbus/LonWorks actuators and VAV-Control	ZTH-GEN
	Belimo PC-Tool, software for adjustments and diagnostics	MFT-P

Electrical installation



- Notes
- Connection via safety isolating transformer.
 - Parallel connection of other actuators possible.
 - Direction of stroke switch factory setting: Actuator spindle retracted.

Wiring diagrams

AC/DC 24V, modulating

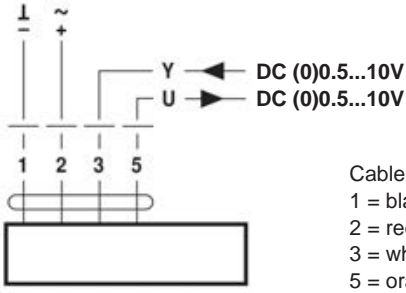

Operation on the MP-Bus

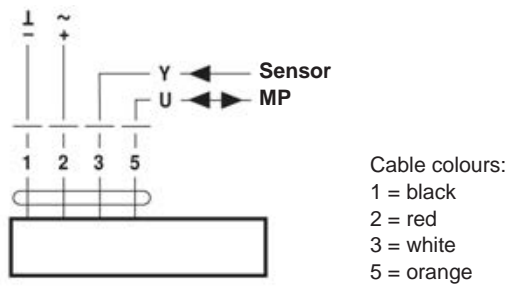

Functions

Functions with basic values

Override control with AC 24V with relay contacts

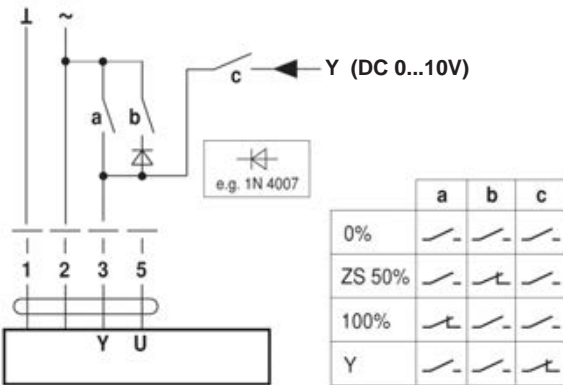

Override control with AC 24V with rotary switch

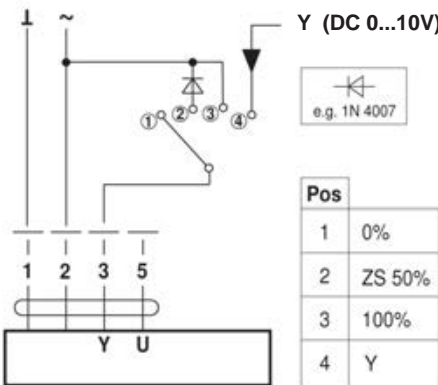

Remote control 0...100%

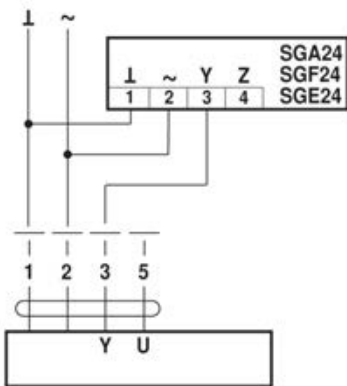

Follow-up control (position-dependent)

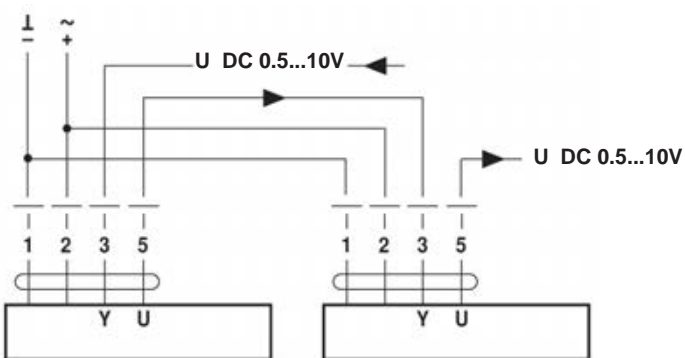

Functions

Control with 4...20mA via external resistor

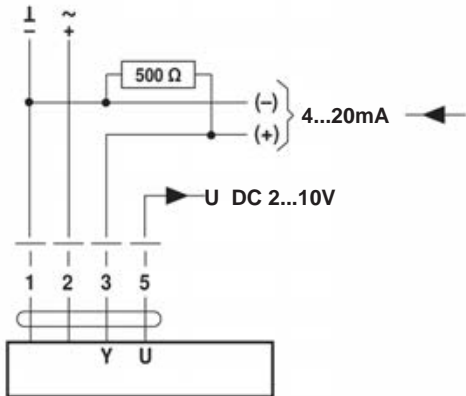

The 500Ω resistor converts the 4...20mA current signal to a voltage signal DC2...10V

Functions for actuators with specific parameters

Override control and limiting with AC 24V with relay contacts

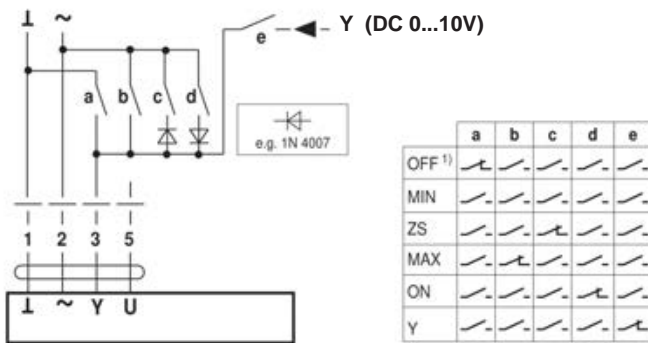

Override control and limiting with AC 24V with rotary switch

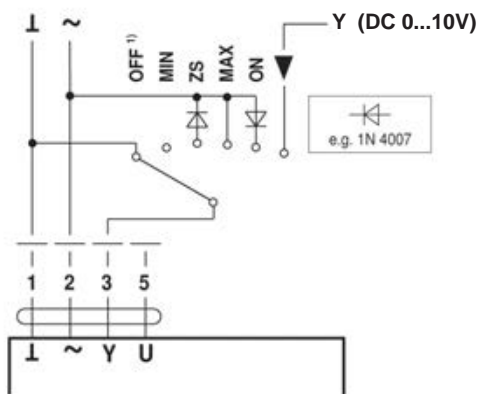

1) Caution: This function is guaranteed only if the start point of the operating range is defined as min. 0.6V.

Functions

AC 24V, 3-point

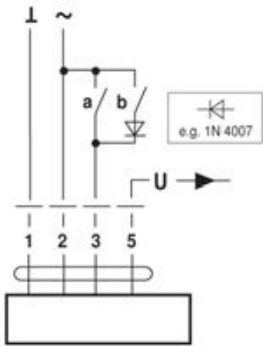

a	b		

Functions when operated on MP-Bus

Connection on the MP-Bus

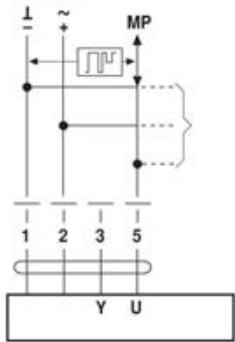

- Supply and communication in one and the same 3-wire cable
- no shielding or twisting required
- no terminating resistor required

Power topology

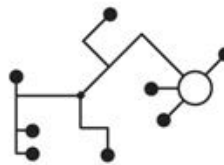

There are no restrictions for the network topology (star, ring, tree or mixed forms are permitted).

Connection of active sensors

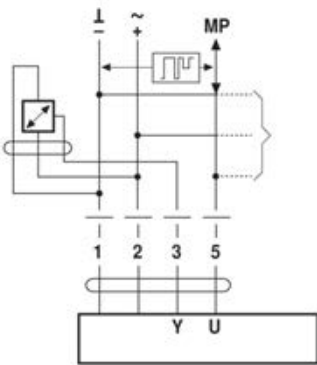

- Supply AC/DC 24V
- Output signal DC 0...10V (max. DC 0...32V)
- Resolution 30mV

Connection of external switching contact

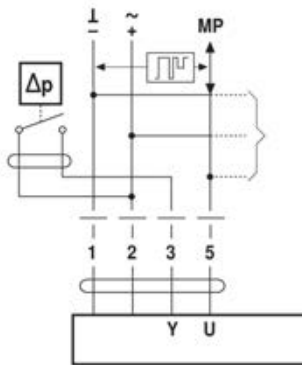

- Switching current 16mA @ 24V
- Start point of the operating range must be parameterised on the MP actuator as $\geq 0.6V$

Connection of passive sensors

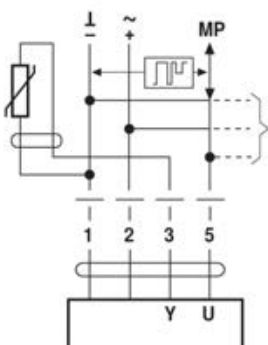

Ni1000	-28 ... +98 °C	850 ... 1600 Ω^2)
PT1000	-35 ... +155 °C	850 ... 1600 Ω^2)
NTC	-10 ... +160 °C ¹⁾	200 Ω ... 50 k Ω^2)

1) Depending on the type
2) Resolution 1 Ohm

Indicators and operating controls

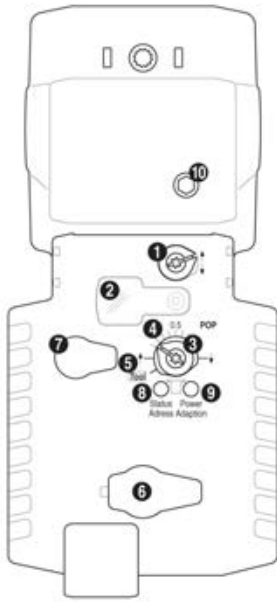

- (1) Direction of stroke switch**
Switching: Direction of stroke changes
- (2) Cover, POP button**
- (3) POP button**
- (4) Scale for manual adjustment**
- (5) Position for adjustment with tool**
- (6) Service plug**
For connecting the parameterisation and service tools
- (7) Gear disengagement button, temporary**
Press button: Gear disengages, motor stops, manual override possible
Release button: Gear engages, standard mode
- (8) Push-button and LED display yellow**
Press button: Confirmation of addressing
- (9) Push-button and LED display green**
Press button: Triggers stroke adaption, followed by standard mode
- (10) Manual override**
Clockwise: Actuator spindle extends
Counterclockwise: Actuator spindle retracts

LED displays (8, yellow) and (9, green)

Yellow: Off; Green: Illuminated; In operation OK

Yellow: Off; Green: Blinking; POP function active

Yellow: Illuminated; Green: Off; Pre-charging time SuperCap / Faulty SuperCap / Wiring error in supply

Yellow: Off; Green: Off; Not in operation

Yellow: Illuminated; Green: Illuminated; Adaption procedure active

Yellow: Flickering; Green: Illuminated; Communication active

Indicators and operating controls

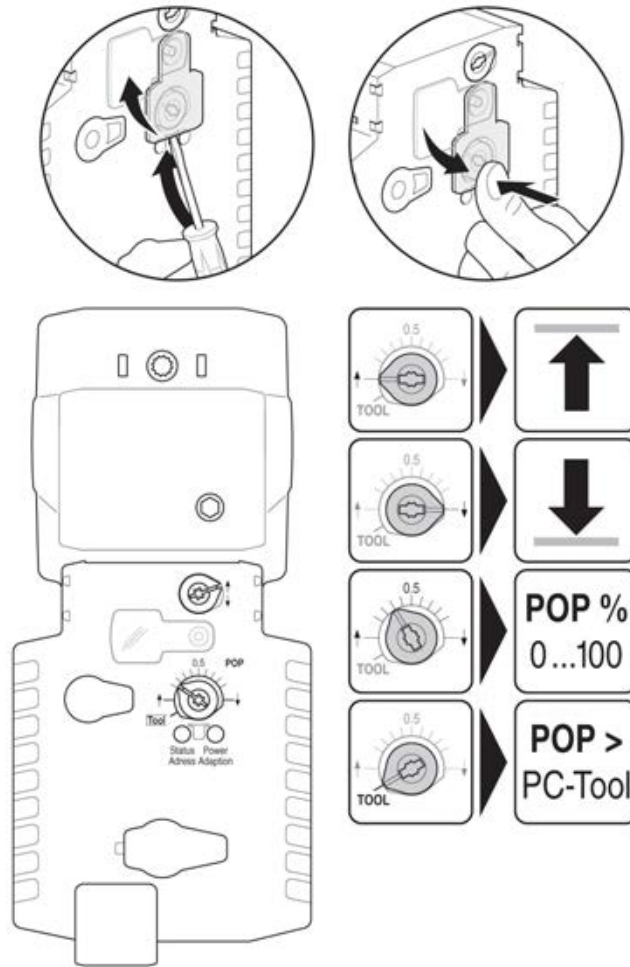

Dimensions [mm]

Dimensional drawings

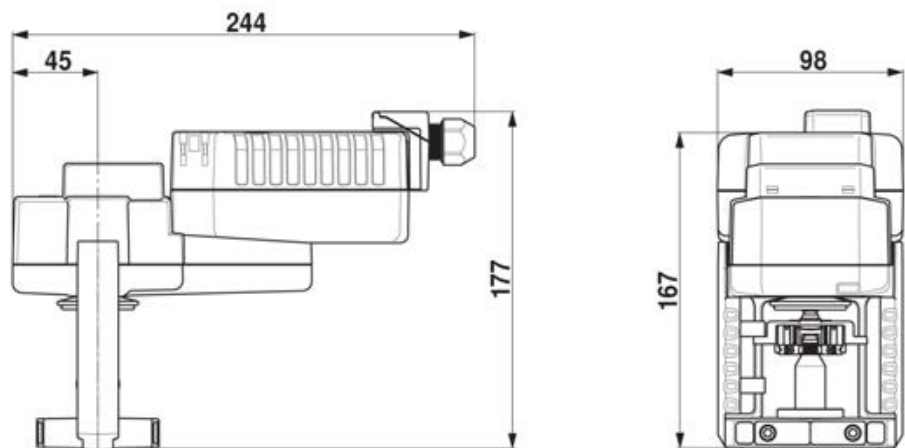

**Globe valve actuator with emergency control function
for 2-way and 3-way globe valves**

- Actuating force 2000N
- Nominal voltage AC/DC 24V
- 3-point control
- Nominal stroke 32mm
- Design life SuperCaps 15 years

Technical data

Electrical data	Nominal voltage	AC/DC 24V	
	Nominal voltage frequency	50/60Hz	
	Nominal voltage range	AC 19.2...28.8V / DC 21.6...28.8V	
	Power consumption in operation	5W	
	Power consumption in rest position	2W	
	Power consumption for wire sizing	9.5VA	
	Connection supply / control	Terminals 4mm ² and cable 1m, 4 x 0.75mm ²	
	Parallel operation	Yes	
Functional data	Actuating force	2000N	
	Adjusting emergency setting position	Actuator spindle retracted / extended, adjustable (POP rotary knob)	
	Manual override	Gear disengagement with push-button	
	Nominal stroke	32mm	
	Actuating time	150s/32mm	
	Actuating time emergency control function	35s/32mm	
	Sound power level motor max.	60dB(A)	
	Sound power level emergency setting position max.	60dB(A)	
	Position indication	Mechanical 5...32mm stroke	
	Safety	Protection class IEC/EN	III Safety extra-low voltage
		Degree of protection IEC/EN	IP54
		EMC	CE in accordance with 2004/108/EC
Certification IEC/EN		Certified to: IEC/EN 60730-1 and IEC/EN 60730-2-14	
Mode of operation		Type 1.AA	
Rated impulse voltage supply / control		0.8kV	
Control pollution degree		3	
Ambient temperature		0°C...50°C	
Non-operating temperature		-40°C...80°C	
Ambient humidity		95% r.h., non-condensing	
Weight	Maintenance	Maintenance-free	
	Weight approx.	4.46kg	

Safety notes

- This actuator has been designed for application in stationary heating, ventilation and air-conditioning systems and is not allowed to be used outside the specified field of application, especially in aircraft or in any other airborne means of transport.
- Only authorised specialists may carry out installation. All applicable legal or institutional installation regulations must be complied with during installation.
- The switch for changing the direction of motion/the closing point may be adjusted only by authorised personnel. The direction of stroke is critical, particularly in connection with frost protection circuits.
- The device may only be opened at the manufacturer's site. It does not contain any parts that can be replaced or repaired by the user.
- The device contains electrical and electronic components and is not allowed to be disposed of as household refuse. All locally valid regulations and requirements must be observed.

Product features

Principle of operation

The actuator moves the valve to the desired operating position at the same time as the integrated capacitors are loaded.

Interrupting the supply voltage causes the valve to be moved to the selected emergency setting position (POP) by means of stored electrical energy.

Pre-charging time (start up)

The capacitor actuators require a pre-charging time. This time is used for charging the capacitors up to a usable voltage level. This ensures that, in the event of an electricity interruption, the actuator can move at any time from its current position into the preset emergency setting position (POP).

The duration of the pre-charging time depends mainly on how long the power was interrupted.

Typical pre-charging time

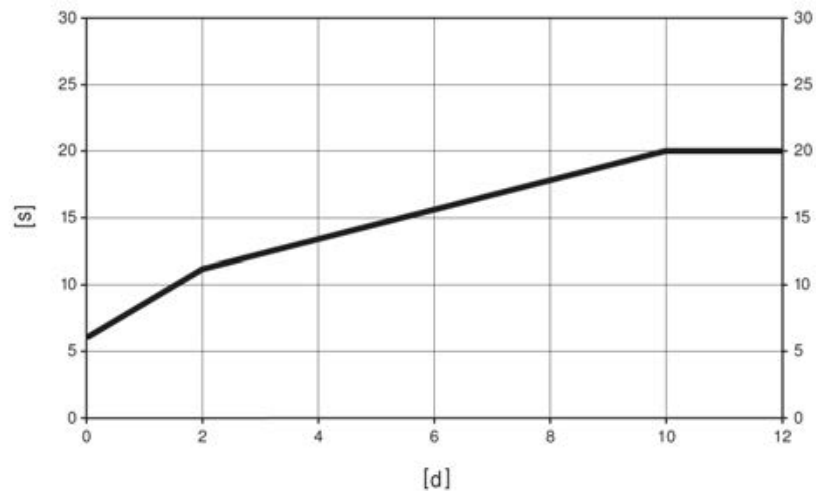

[d] = Electricity interruption in days
 [s] = Pre-charging time in seconds
 PF[s] = Bridging time

	[d]				
	0	1	2	7	≥10
[s]	6	9	11	16	20

Delivery condition (capacitors)

The actuator is completely discharged after delivery from the factory, which is why the actuator requires approximately 20s pre-charging time before initial commissioning in order to bring the capacitors up to the required voltage level.

Direct mounting

Simple direct mounting on the globe valve by means of form-fit hollow clamping jaws. The actuator can be rotated through 360° on the valve neck.

Manual override

Manual override with push-button possible - temporary. The gear is disengaged and the actuator decoupled for as long as the button is pressed.

The stroke can be adjusted by using a hexagon socket screw key (5mm), which is inserted into the top of the actuator. The stroke spindle extends when the key is rotated clockwise.

High functional reliability

The actuator is overload protected, requires no limit switches and automatically stops when the end stop is reached.

Combination valve/actuator

Refer to the valve documentation for suitable valves, their permitted medium temperatures and closing pressures.

Position indication

The stroke is indicated mechanically on the bracket with tabs. The stroke range adjusts itself automatically during operation.

Home position

Setting ex-works: Actuator spindle is retracted.
 When valve-actuator combinations are shipped, the direction of motion is set in accordance with the closing point of the valve.

Direction of stroke switch

When actuated, the direction of stroke switch changes the running direction in normal operation. The direction of stroke switch has no influence on the emergency setting position (POP) which has been set.

Rotary knob emergency setting position

The "Emergency setting position" rotary knob can be used to adjust the desired emergency setting position (POP). The POP range is in reference to the maximum height of stroke of the actuator.

In the event of an electricity interruption, the actuator will move into the selected emergency setting position, taking into account the bridging time (PF) of 2s which was set ex-works.

Accessories

Electrical accessories

Description

Type

Auxiliary switch add-on, 2 x SPDT

S2A-H

Electrical installation



- Notes
- Connection via safety isolating transformer.
 - Parallel connection of other actuators possible
 - Direction of stroke switch factory setting: Actuator spindle retracted.

Wiring diagrams

AC/DC 24V, 3-point

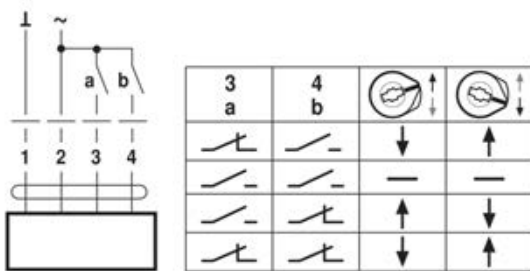

Cable colours:

- 1 = black
- 2 = red
- 3 = white
- 4 = white

Indicators and operating controls

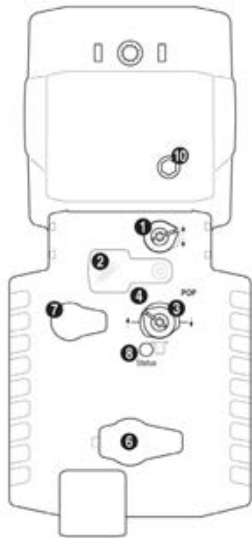

- (1) Direction of stroke switch**
Switching: Direction of stroke changes
- (2) Cover, POP button**
- (3) POP button**
- (4) Scale for manual adjustment**
- (6) No function**
- (7) Gear disengagement button, temporary**
Press button: Gear disengages, motor stops, manual override possible
Release button: Gear engages, standard mode
- (8) LED displays**
Green: Off; Not in operation / Pre-charging time SuperCap / Faulty SuperCap
Green: Illuminated; In operation OK
Green: Blinking; POP function active
- (10) Manual override**
Clockwise: Actuator spindle extends
Counterclockwise: Actuator spindle retracts

Indicators and operating controls

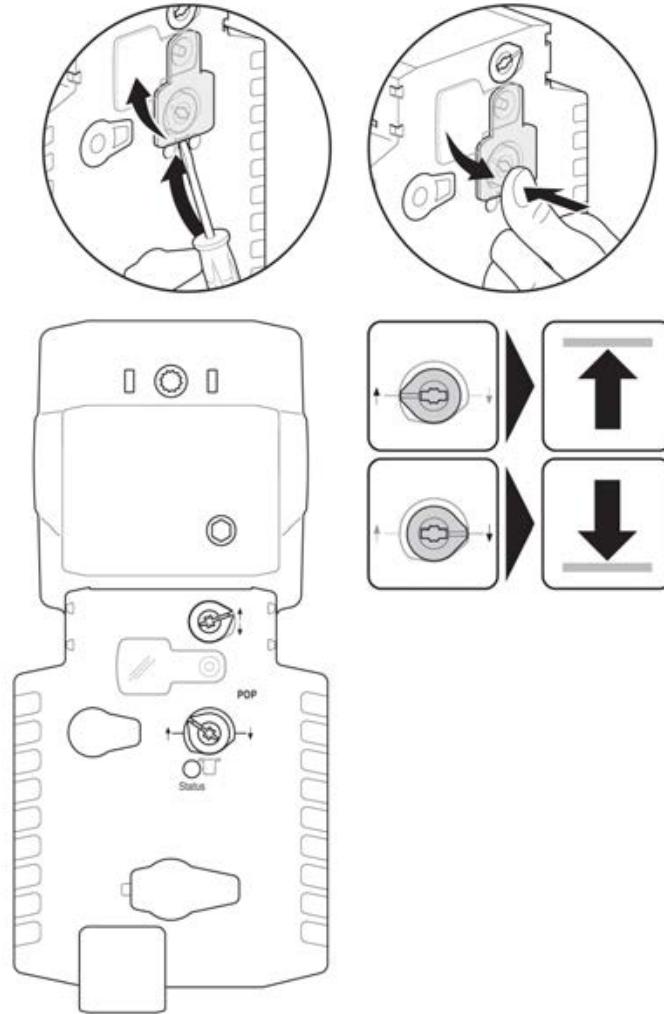

Dimensions [mm]

Dimensional drawings

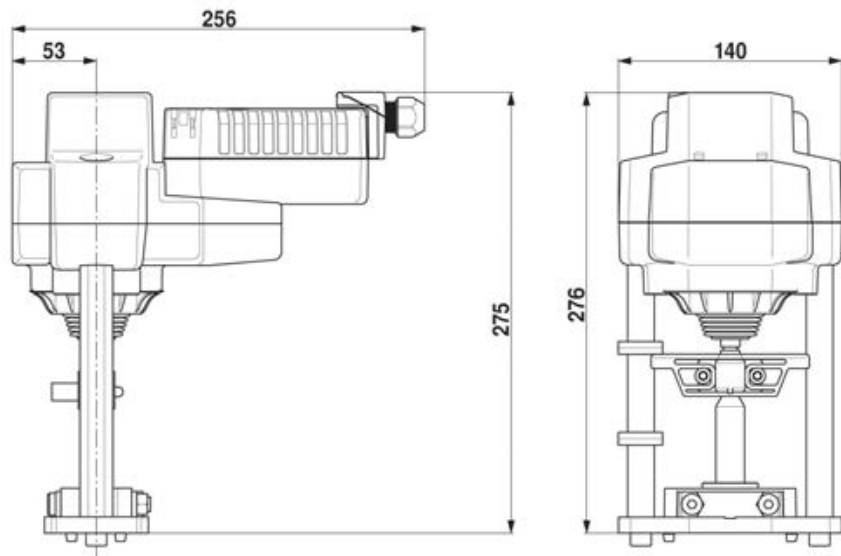

**Globe valve actuator with emergency control function
for 2-way and 3-way globe valves**

- Actuating force 2000N
- Nominal voltage AC 230V
- 3-point control
- Nominal stroke 32mm
- Design life SuperCaps 15 years

Technical data

Electrical data	Nominal voltage	AC 230V	
	Nominal voltage frequency	50/60Hz	
	Nominal voltage range	AC 198...264V	
	Power consumption in operation	3.5W	
	Power consumption in rest position	1.5W	
	Power consumption for wire sizing	6.5VA	
	Connection supply / control	Cable 1m, 4 x 0.75mm ²	
Functional data	Parallel operation	Yes	
	Actuating force	2000N	
	Adjusting emergency setting position	Actuator spindle retracted / extended, adjustable (POP rotary knob)	
	Manual override	Gear disengagement with push-button	
	Nominal stroke	32mm	
	Actuating time	150s/32mm	
	Actuating time emergency control function	35s/32mm	
	Sound power level motor max.	60dB(A)	
	Sound power level emergency setting position max.	60dB(A)	
	Position indication	Mechanical 5...32mm stroke	
	Safety	Protection class IEC/EN	II protective insulated
		Degree of protection IEC/EN	IP54
		EMC	CE according to 2004/108/EC
Certification IEC/EN		Certified to: IEC/EN 60730-1 and IEC/EN 60730-2-14	
Mode of operation		Type 1.AA	
Rated impulse voltage supply / control		4kV	
Control pollution degree		3	
Ambient temperature		0°C...50°C	
Non-operating temperature		-40°C...80°C	
Ambient humidity		95% r.h., non-condensing	
Weight	Maintenance	Maintenance-free	
	Weight approx.	4.4kg	

Safety notes

- This actuator has been designed for application in stationary heating, ventilation and air-conditioning systems and is not allowed to be used outside the specified field of application, especially not in aircraft or in any other airborne means of transport.
- Only authorised specialists may carry out installation. All applicable legal or institutional installation regulations must be complied with during installation.
- The switch for changing the direction of motion/the closing point may be adjusted only by authorised personnel. The direction of stroke is critical, particularly in connection with frost protection circuits.
- The device may only be opened at the manufacturer's site. It does not contain any parts that can be replaced or repaired by the user.
- The cable must not be removed from the device.
- The device contains electrical and electronic components and is not allowed to be disposed of as household refuse. All locally valid regulations and requirements must be observed.

Product features

Mode of operation

The actuator moves the valve to the desired operating position at the same time as the integrated capacitors are loaded.

Interrupting the supply voltage causes the valve to be moved to the selected emergency setting position (POP) by means of stored electrical energy.

Pre-charging time (start up)

The capacitor actuators require a pre-charging time. This time is used for charging the capacitors up to a usable voltage level. This ensures that, in the event of an electricity interruption, the actuator can move at any time from its current position into the preset emergency setting position (POP).

The duration of the pre-charging time depends mainly on how long the power was interrupted.

Typical pre-charging time

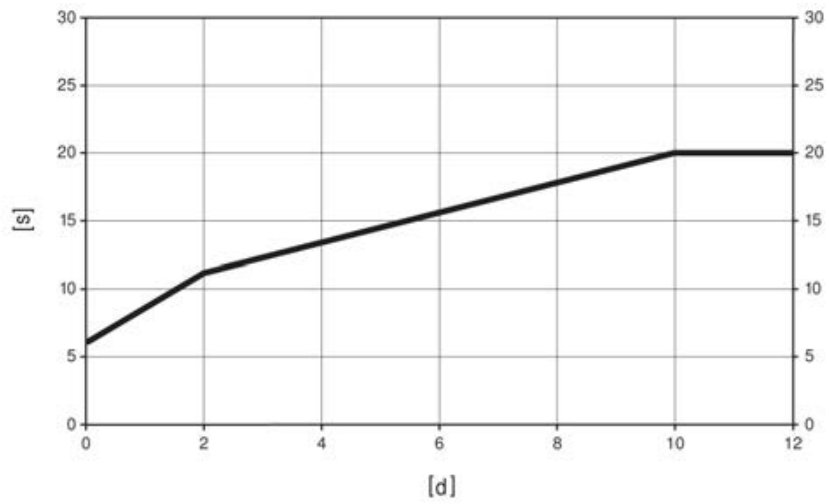

[d] = Electricity interruption in days
 [s] = Pre-charging time in seconds
 PF[s] = Bridging time

	[d]				
	0	1	2	7	≥10
[s]	6	9	11	16	20

Delivery condition (capacitors)

The actuator is completely discharged after delivery from the factory, which is why the actuator requires approximately 20s pre-charging time before initial commissioning in order to bring the capacitors up to the required voltage level.

Direct mounting

Simple direct mounting on the globe valve by means of form-fit hollow clamping jaws. The actuator can be rotated through 360° on the valve neck.

Manual override

Manual override with push-button possible - temporary. The gear is disengaged and the actuator decoupled for as long as the button is pressed.

The stroke can be adjusted by using a hexagon socket screw key (5mm), which is inserted into the top of the actuator. The stroke spindle extends when the key is rotated clockwise.

High functional reliability

The actuator is overload protected, requires no limit switches and automatically stops when the end stop is reached.

Combination valve/actuator

Refer to the valve documentation for suitable valves, their permitted medium temperatures and closing pressures.

Position indication

The stroke is indicated mechanically on the bracket with tabs. The stroke range adjusts itself automatically during operation.

Home position

Setting ex-works: Actuator spindle is retracted.
 When valve-actuator combinations are shipped, the direction of motion is set in accordance with the closing point of the valve.

Direction of stroke switch

When actuated, the direction of stroke switch changes the running direction in normal operation. The direction of stroke switch has no influence on the emergency setting position (POP) which has been set.

Rotary knob emergency setting position

The "Emergency setting position" rotary knob can be used to adjust the desired emergency setting position (POP). The POP range is in reference to the maximum height of stroke of the actuator.

In the event of an electricity interruption, the actuator will move into the selected emergency setting position, taking into account the bridging time (PF) of 2s which was set ex-works.

Accessories

Electrical accessories

Description

Type

Auxiliary switch add-on, 2 x SPDT

S2A-H

Electrical installation



- Notes • Parallel connection of other actuators possible
- Direction of stroke switch factory setting: Actuator spindle retracted.

Wiring diagrams

AC 230V, 3-point

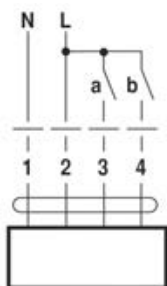

3 a	4 b		
		—	—
		↑	↓
		↓	↑

Cable colours:

- 1 = blue
- 2 = brown
- 3 = white
- 4 = white

Indicators and operating controls

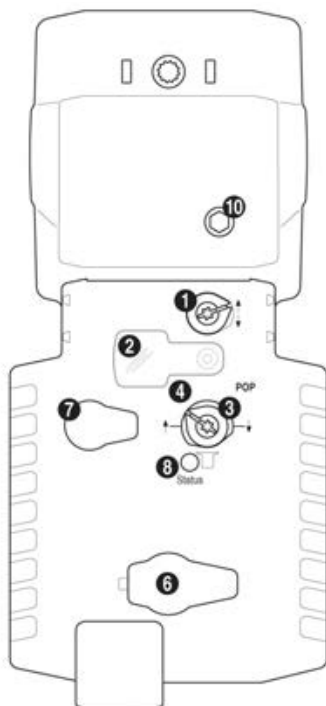

- (1) **Direction of stroke switch**
Switching: Direction of stroke changes
- (2) **Cover, POP button**
- (3) **POP button**
- (4) **Scale for manual adjustment**
- (6) **No function**
- (7) **Gear disengagement button, temporary**
Press button: Gear disengages, motor stops, manual override possible
Release button: Gear engages, standard mode
- (8) **LED displays**
green: Off; Not in operation / Pre-charging time SuperCap / Faulty SuperCap
green: Illuminated; In operation OK
green: Blinking; POP function active
- (10) **Manual override**
Clockwise: Actuator spindle extends
Counterclockwise: Actuator spindle retracts

Indicators and operating controls

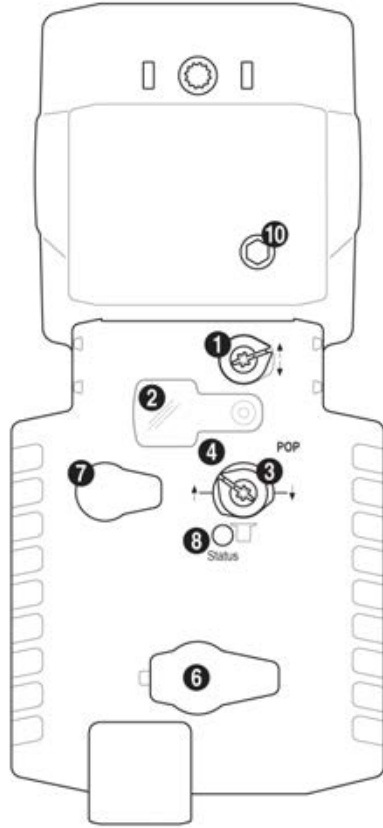

Dimensions [mm]

Dimensional drawings

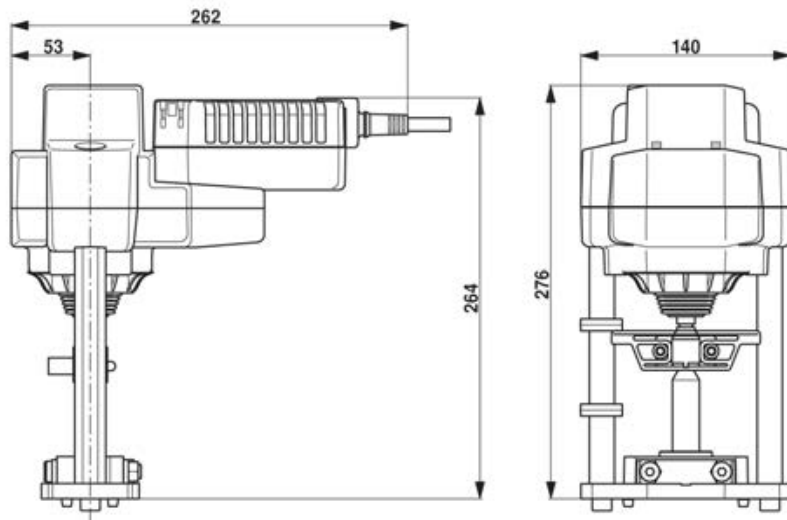

Communication-capable globe valve actuator with emergency control function for 2-way and 3-way globe valves

- Actuating force 2000N
- Nominal voltage AC/DC 24V
- Control modulating DC (0)0.5V...10V, variable
- Nominal stroke 32mm
- Design life SuperCaps 15 years

Technical data

Electrical data	Nominal voltage	AC/DC 24V
	Nominal voltage frequency	50/60Hz
	Nominal voltage range	AC 19.2...28.8V / DC 21.6...28.8V
	Power consumption in operation	5W
	Power consumption in rest position	2W
	Power consumption for wire sizing	9.5VA
	Connection supply / control	Terminals 4mm ² and cable 1m, 4 x 0.75mm ²
	Parallel operation	Yes
Functional data	Actuating force	2000N
	Positioning signal Y	DC 0...10V
	Positioning signal Y note	Input impedance 100kΩ
	Operating range Y	DC 0.5...10V
	Operating range Y variable	Start point DC 0.5...30V
		End point DC 2.5...32V
	Position feedback U	DC 0.5...10V
	Position feedback U note	max. 0.5mA
	Position feedback U variable	Start point DC 0.5...8V
		End point DC 2.5...10V
	Adjusting emergency setting position	Actuator spindle 0...100%, adjustable (POP rotary knob)
	Bridging time (PF) variable	1...10s
	Position accuracy	5% absolute
	Manual override	Gear disengagement with push-button
	Nominal stroke	32mm
	Actuating time	150s/32mm
	Actuating time emergency control function	35s/32mm
	Override control MAX (maximum position)	100%
	Override control MIN (minimum position)	0%
	Override control ZS (intermediate position, only AC)	50%
	Override control ZS variable	ZS = MIN...MAX
	Sound power level motor max.	60dB(A)
Sound power level motor note	60dB(A) @ 90s running time	
Sound power level emergency setting position max.	60dB(A)	
Position indication	Mechanical 5...32mm stroke	
Safety	Service life design life	15 years
	Protection class IEC/EN	III Safety extra-low voltage
	Degree of protection IEC/EN	IP54
	EMC	CE in accordance with 2004/108/EC
	Certification IEC/EN	Certified to: IEC/EN 60730-1 and IEC/EN 60730-2-14
	Mode of operation	Type 1.AA
	Rated impulse voltage supply / control	0.8kV

Technical data

Safety	Control pollution degree	3
	Ambient temperature	0°C...50°C
	Non-operating temperature	-40°C...80°C
	Ambient humidity	95% r.h., non-condensing
Weight	Maintenance	Maintenance-free
	Weight approx.	4.46kg

Safety notes



- This actuator has been designed for application in stationary heating, ventilation and air-conditioning systems and is not allowed to be used outside the specified field of application, especially in aircraft or in any other airborne means of transport.
- Only authorised specialists may carry out installation. All applicable legal or institutional installation regulations must be complied with during installation.
- The switch for changing the direction of motion/the closing point may be adjusted only by authorised personnel. The direction of stroke is critical, particularly in connection with frost protection circuits.
- The device may only be opened at the manufacturer's site. It does not contain any parts that can be replaced or repaired by the user.
- The device contains electrical and electronic components and is not allowed to be disposed of as household refuse. All locally valid regulations and requirements must be observed.

Product features

Principle of operation

The actuator is connected with a standard modulating signal of DC 0...10V and travels to the position defined by the positioning signal at the same time the integrated capacitors are being charged.

Interrupting the supply voltage causes the valve to be moved to the selected emergency setting position (POP) by means of stored electrical energy.

Pre-charging time (start up)

The capacitor actuators require a pre-charging time. This time is used for charging the capacitors up to a usable voltage level. This ensures that, in the event of an electricity interruption, the actuator can move at any time from its current position into the preset emergency setting position (POP).

The duration of the pre-charging time depends mainly on the following factors:

- Duration of the voltage interruption
- PF delay time (bridging time)

Typical pre-charging time

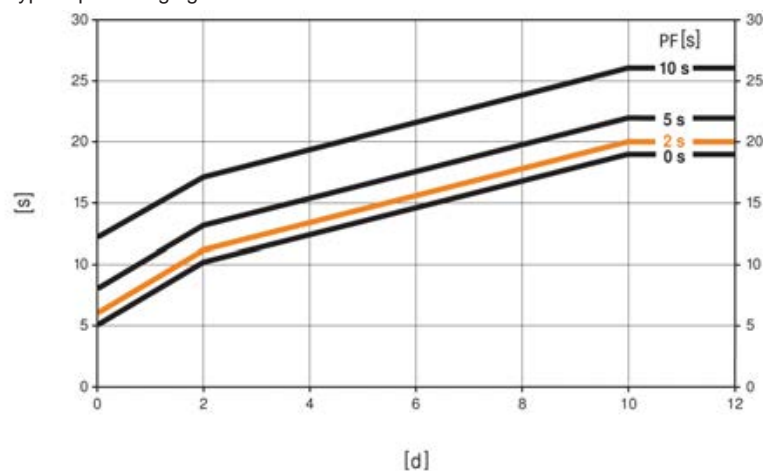

PF [s]	[d]				
	0	1	2	7	≥10
0	5	8	10	15	19
2	6	9	11	16	20
5	8	11	13	18	22
10	12	15	17	22	26

[s]

[d] = Electricity interruption in days

[s] = Pre-charging time in seconds

PF[s] = Bridging time

Calculation example: In the event of an electricity interruption of 3 days and a set bridging time (PF) of 5s, the actuator requires a pre-charging time of 14s (see graphic) after the voltage has been reconnected.

Product features

Delivery condition (capacitors)	The actuator is completely discharged after delivery from the factory, which is why the actuator requires approximately 20s pre-charging time before initial commissioning in order to bring the capacitors up to the required voltage level.
Adjustable-parameter actuators	The factory settings cover the most common applications. Input and output signals and other parameters can be altered with the PC-Tool MFT-P or with the service tool ZTH-GEN.
 Direct mounting	Simple direct mounting on the globe valve by means of form-fit hollow clamping jaws. The actuator can be rotated through 360° on the valve neck.
 Manual override	Manual override with push-button possible - temporary. The gear is disengaged and the actuator decoupled for as long as the button is pressed. The stroke can be adjusted by using a hexagon socket screw key (5mm), which is inserted into the top of the actuator. The stroke spindle extends when the key is rotated clockwise.
High functional reliability	The actuator is overload protected, requires no limit switches and automatically stops when the end stop is reached.
Combination valve/actuator	Refer to the valve documentation for suitable valves, their permitted medium temperatures and closing pressures.
 Position indication	The stroke is indicated mechanically on the bracket with tabs. The stroke range adjusts itself automatically during operation.
 Home position	Setting ex-works: Actuator spindle is retracted. When valve-actuator combinations are shipped, the direction of motion is set in accordance with the closing point of the valve.
Direction of stroke switch	When actuated, the direction of stroke switch changes the running direction in normal operation. The direction of stroke switch has no influence on the emergency setting position (POP) which has been set.
Adaption of stroke range	The first time the supply voltage is switched on, i.e. at the time of commissioning, the actuator carries out a stroke adaption, which is when the operating range and position feedback adjust themselves to the mechanical stroke. Manual triggering of the adaption can be carried out by pressing the "Adaption" button or with the PC-Tool. The actuator then moves into the position defined by the positioning signal.
Rotary knob emergency setting position	The "Emergency setting position" rotary knob can be used to adjust the desired emergency setting position (POP) from 0% to 100% in 10% increments. The rotary knob is in reference to the adapted or programmed height of stroke. In the event of an electricity interruption, the actuator will move into the selected emergency setting position, taking into account the bridging time (PF) of 2s which was set ex-works. Settings: The rotary knob must be set to the "Tool" position for retroactive settings of the emergency setting position with the Belimo service tool MFT-P. Once the rotary knob is set back to the range 0...100%, the manually set value will have positioning authority.
 Bridging time (PF)	Electricity interruptions can be bridged up to a maximum of 10s. In the event of an electricity interruption, the actuator will remain stationary in accordance with the set bridging time. If the electricity interruption is greater than the set bridging time, then the actuator will move into the selected emergency setting position (POP). The bridging time set ex-works is 2s. This can be modified at the site of operations with the use of the Belimo service tool MFT-P. Settings: The rotary knob must not be set to the "Tool" position! Only the values need to be entered for retroactive adjustments of the bridging time with the Belimo service tool MFT-P.

Accessories

Electrical accessories	Description	Type
	Auxiliary switch add-on, 2 x SPDT	S2A-H
Service tools	Manual parameterising device, for MF/MP/Modbus/LonWorks actuators and VAV-Control	ZTH-GEN
	Belimo PC-Tool, software for adjustments and diagnostics	MFT-P

Electrical installation



- Notes
- Connection via safety isolating transformer.
 - Parallel connection of other actuators possible.
 - Direction of stroke switch factory setting: Actuator spindle retracted.

Wiring diagrams

AC/DC 24V, modulating

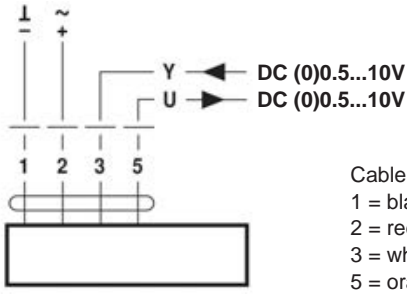

Operation on the MP-Bus

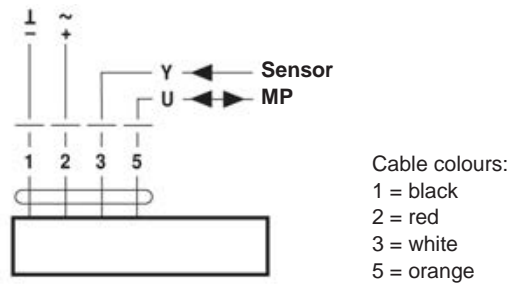

Functions

Functions with basic values

Override control with AC 24V with relay contacts

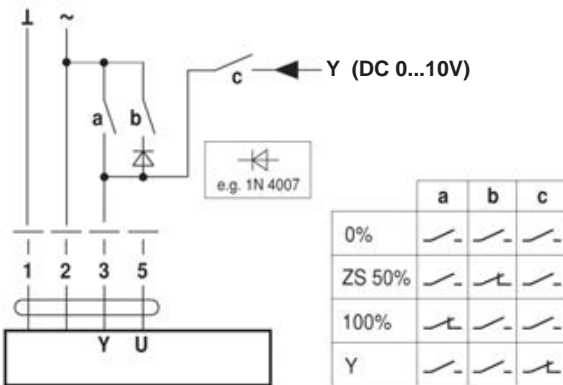

Override control with AC 24V with rotary switch

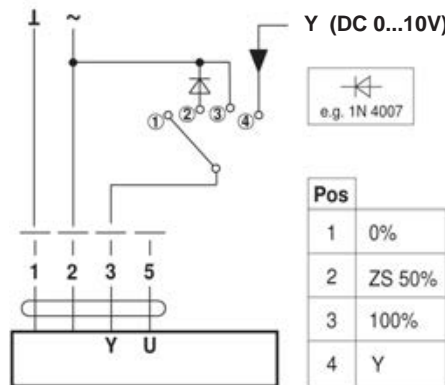

Remote control 0...100%

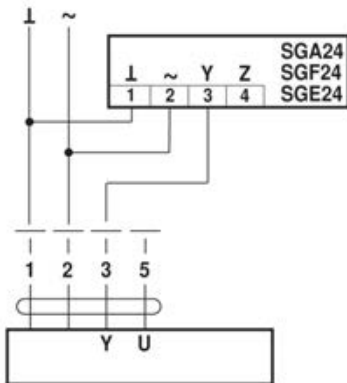

Follow-up control (position-dependent)

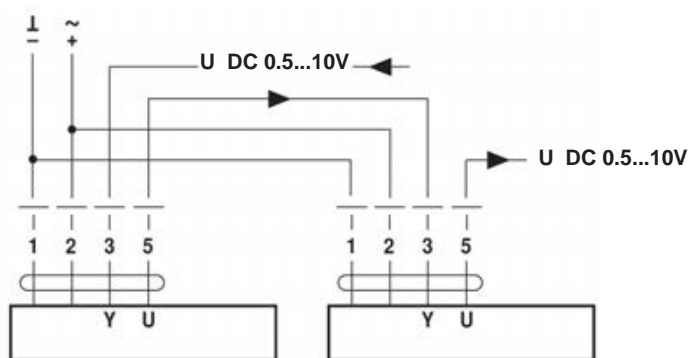

Functions

Control with 4...20mA via external resistor

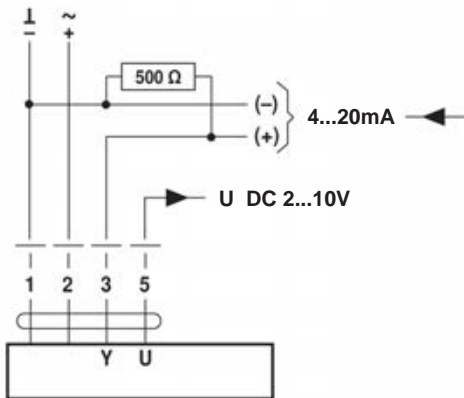

The 500Ω resistor converts the 4...20mA current signal to a voltage signal DC2...10V

Functions for actuators with specific parameters

Override control and limiting with AC 24V with relay contacts

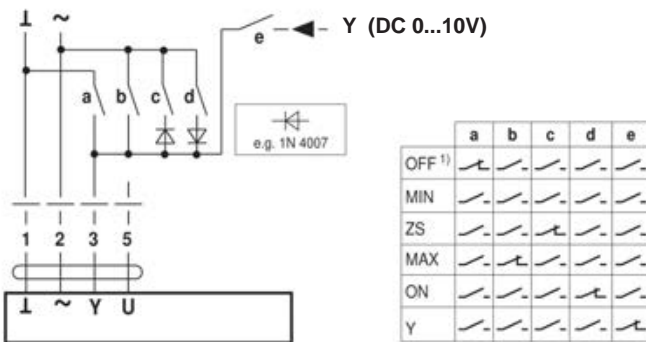

Override control and limiting with AC 24V with rotary switch

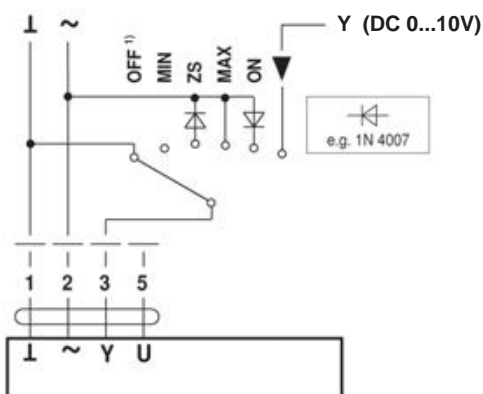

1) Caution: This function is guaranteed only if the start point of the operating range is defined as min. 0.6V.

Functions

AC 24V, 3-point

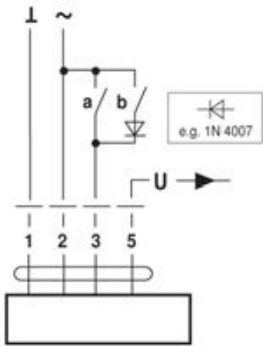

a	b		
		↓	↑
		—	—
		↑	↓
		↓	↑

Functions when operated on MP-Bus

Connection on the MP-Bus

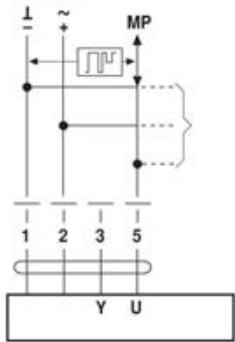

- Supply and communication in one and the same 3-wire cable
- no shielding or twisting required
- no terminating resistor required

Power topology

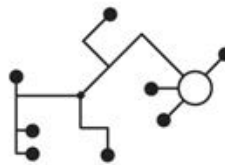

There are no restrictions for the network topology (star, ring, tree or mixed forms are permitted).

Connection of active sensors

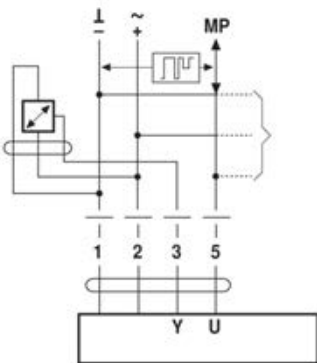

- Supply AC/DC 24V
- Output signal DC 0...10V (max. DC 0...32V)
- Resolution 30mV

Connection of external switching contact

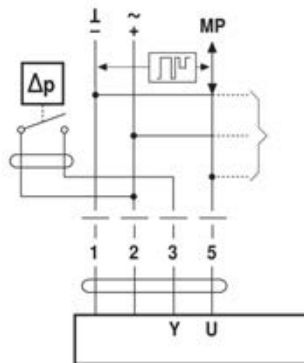

- Switching current 16mA @ 24V
- Start point of the operating range must be parameterised on the MP actuator as $\geq 0.6V$

Connection of passive sensors

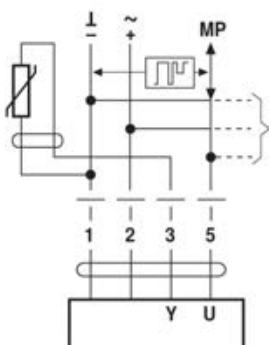

Ni1000	-28 ... +98 °C	850 ... 1600 Ω^2)
PT1000	-35 ... +155 °C	850 ... 1600 Ω^2)
NTC	-10 ... +160 °C ¹⁾	200 Ω ... 50 k Ω^2)

1) Depending on the type
2) Resolution 1 Ohm

Indicators and operating controls

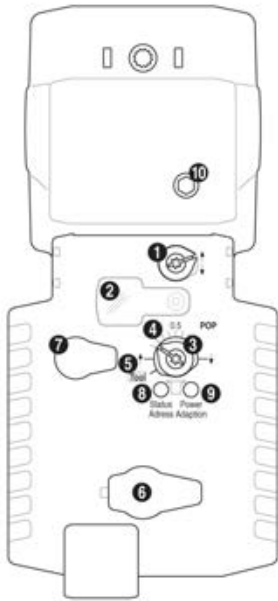

- (1) Direction of stroke switch**
Switching: Direction of stroke changes
- (2) Cover, POP button**
- (3) POP button**
- (4) Scale for manual adjustment**
- (5) Position for adjustment with tool**
- (6) Service plug**
For connecting the parameterisation and service tools
- (7) Gear disengagement button, temporary**
Press button: Gear disengages, motor stops, manual override possible
Release button: Gear engages, standard mode
- (8) Push-button and LED display yellow**
Press button: Confirmation of addressing
- (9) Push-button and LED display green**
Press button: Triggers stroke adaption, followed by standard mode
- (10) Manual override**
Clockwise: Actuator spindle extends
Counterclockwise: Actuator spindle retracts

LED displays (8, yellow) and (9, green)

Yellow: Off; Green: Illuminated; In operation OK

Yellow: Off; Green: Blinking; POP function active

Yellow: Illuminated; Green: Off; Pre-charging time SuperCap / Faulty SuperCap / Wiring error in supply

Yellow: Off; Green: Off; Not in operation

Yellow: Illuminated; Green: Illuminated; Adaption procedure active active

Yellow: Flickering; Green: Illuminated; Communication active

Indicators and operating controls

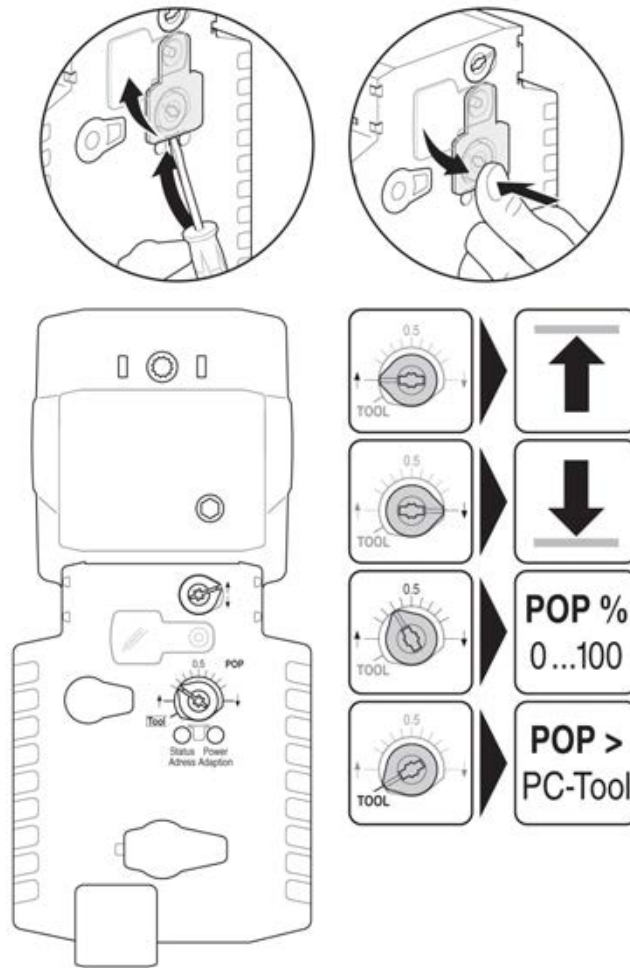

Dimensions [mm]

Dimensional drawings

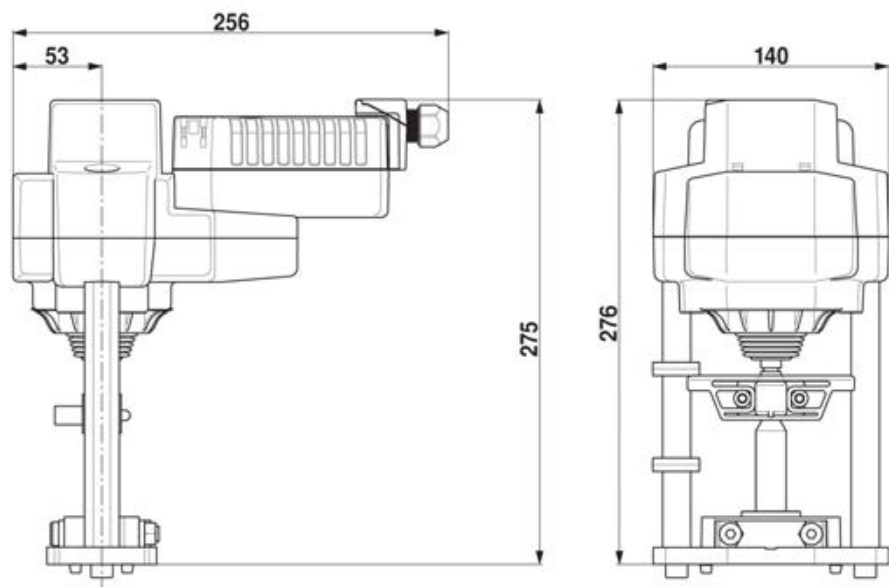

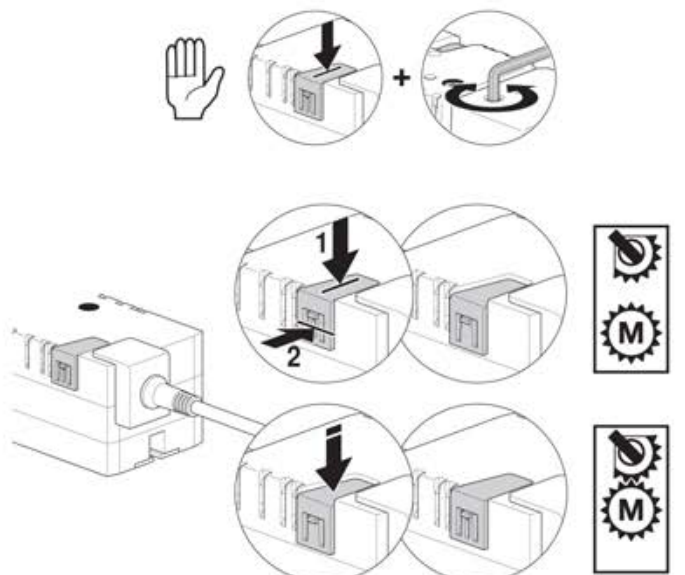
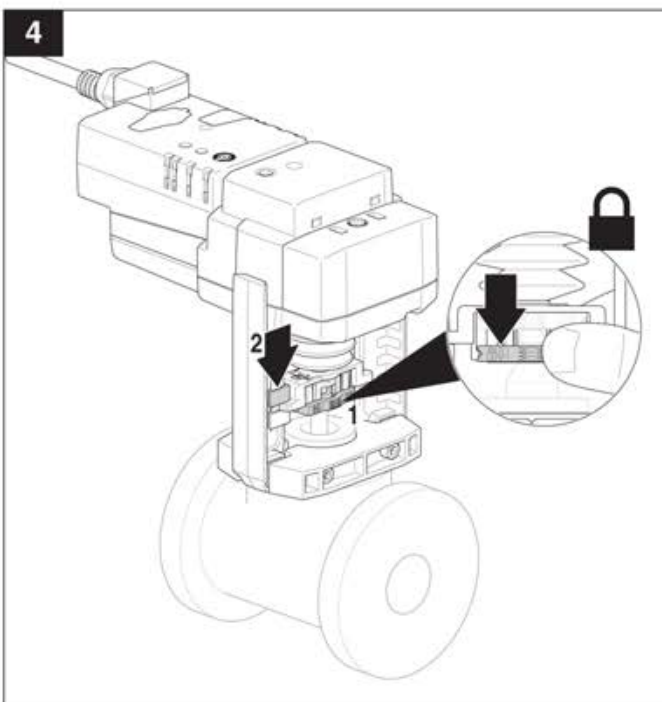
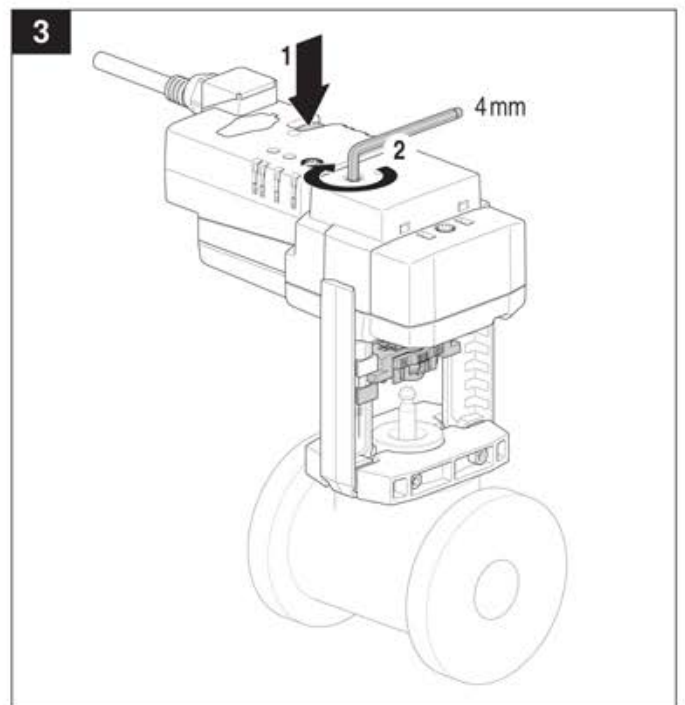
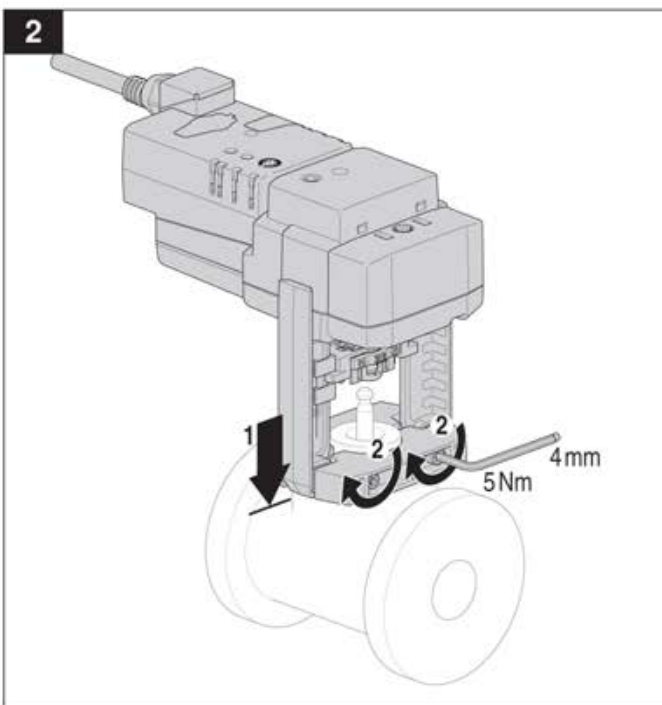
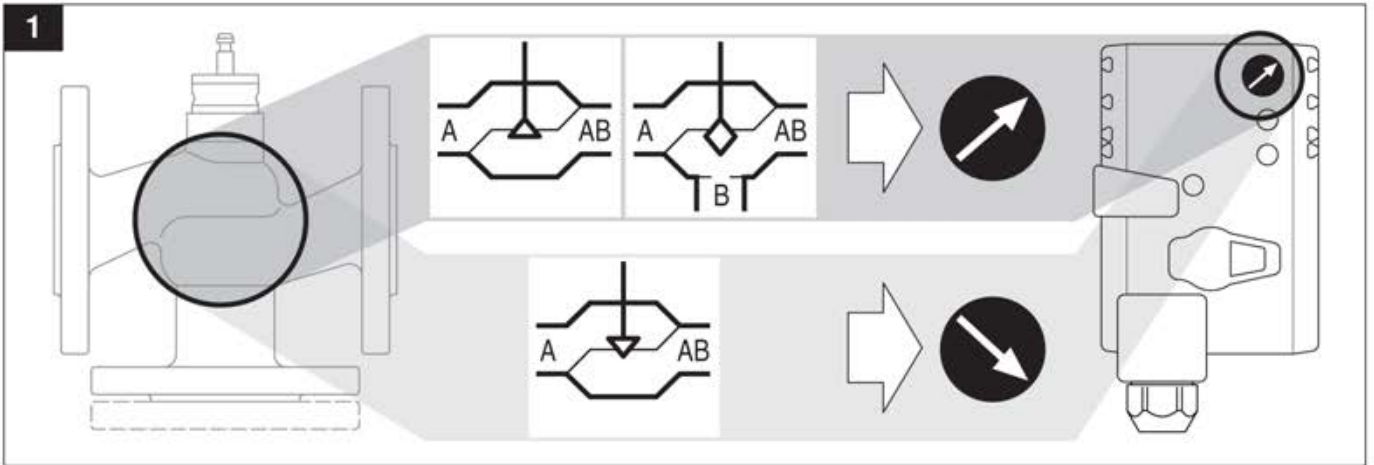

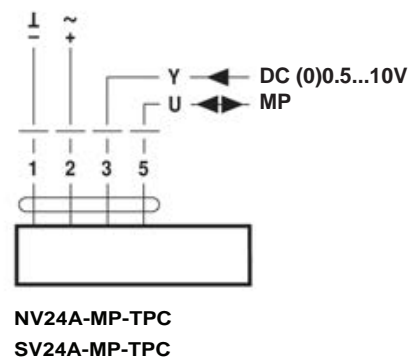
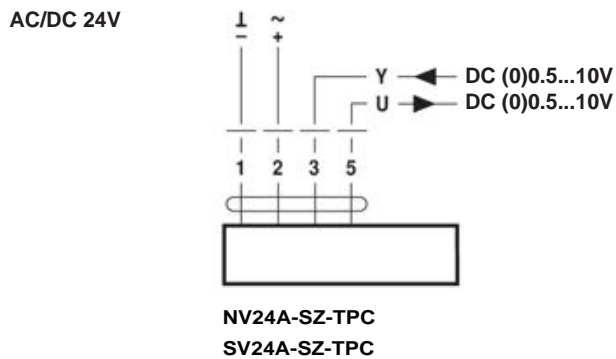
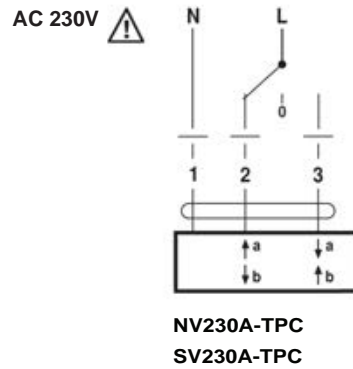
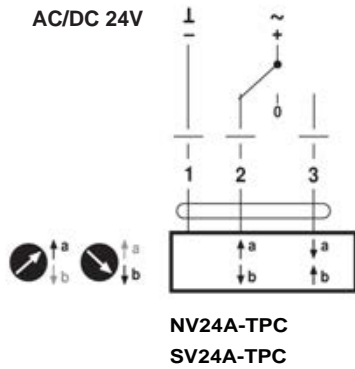
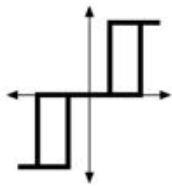
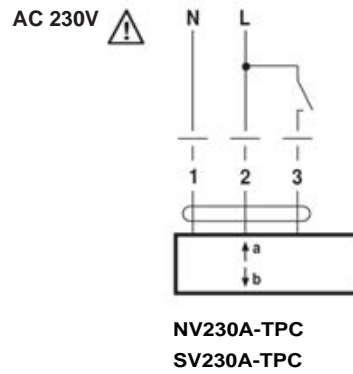
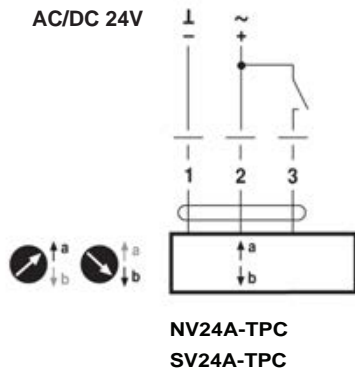

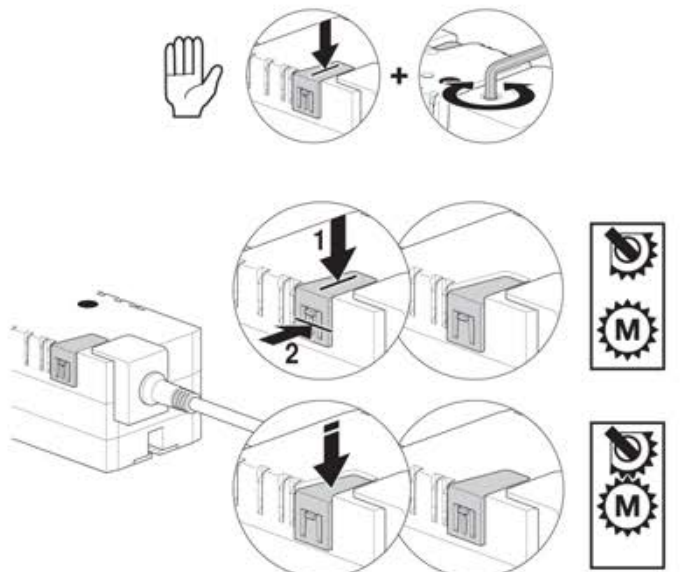
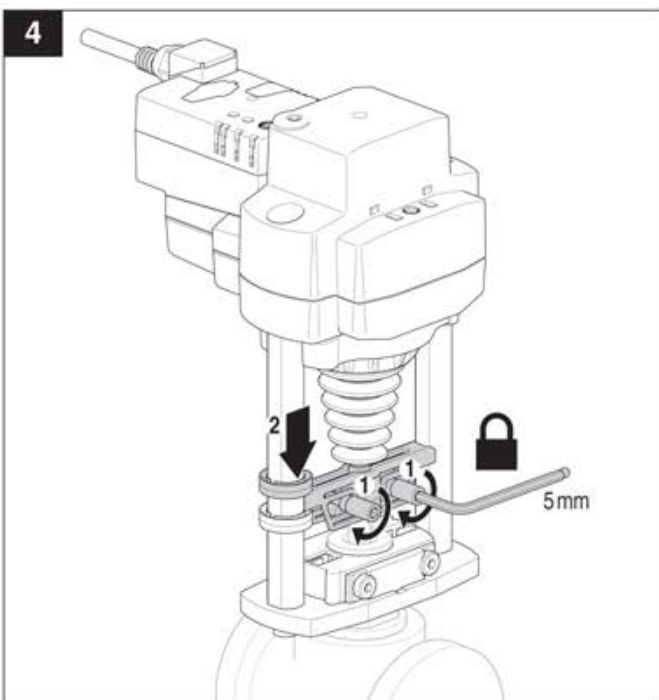
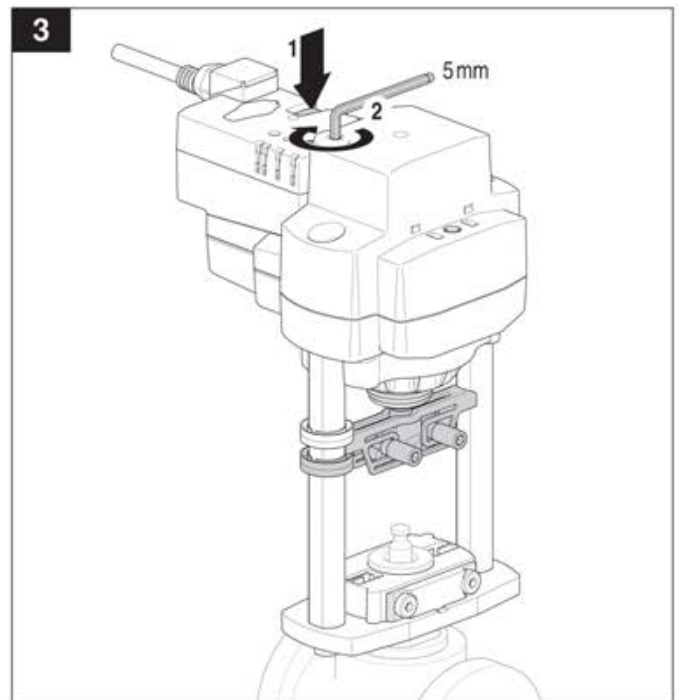
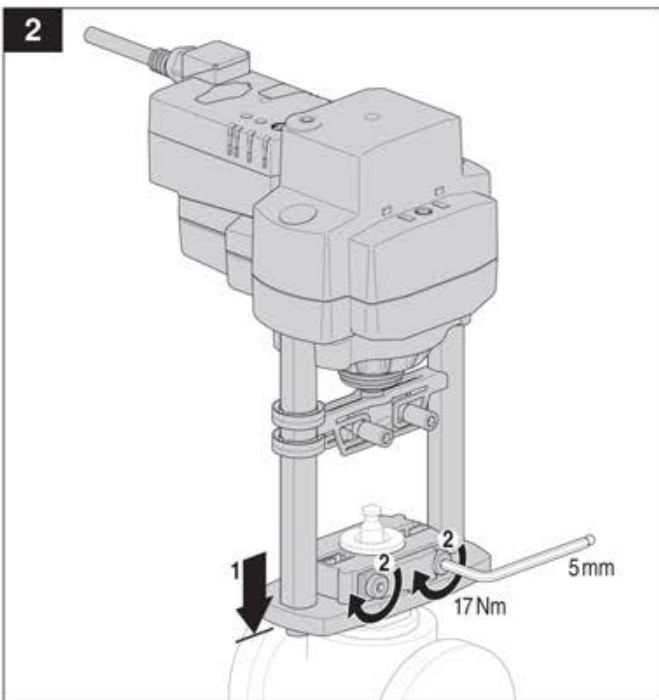
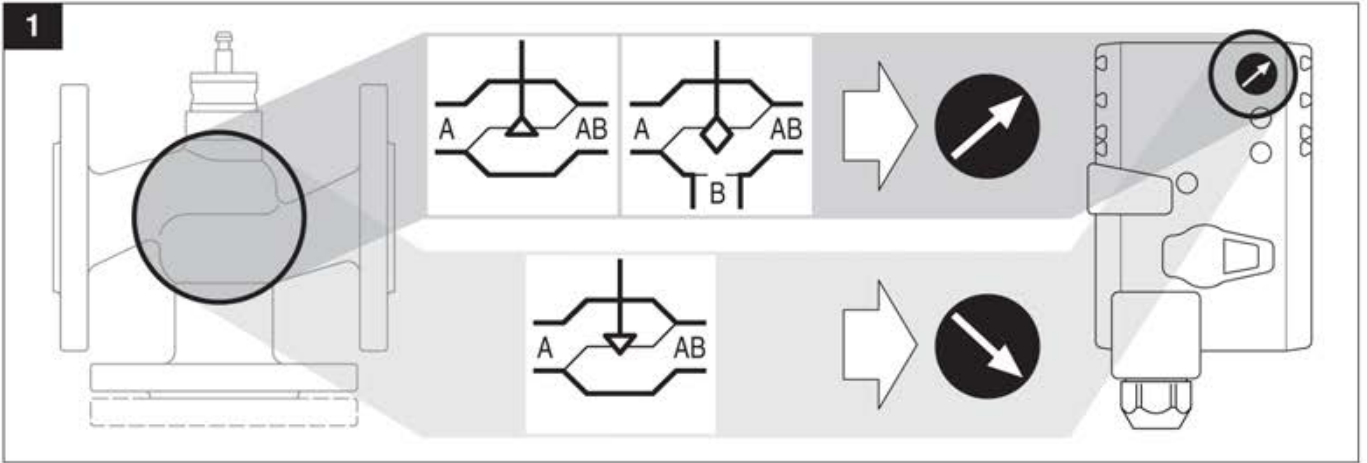

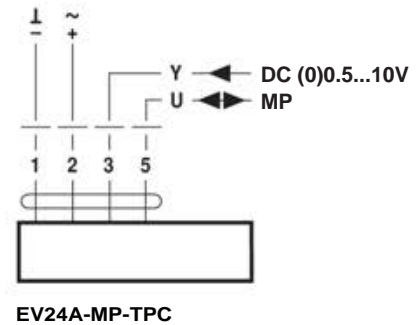
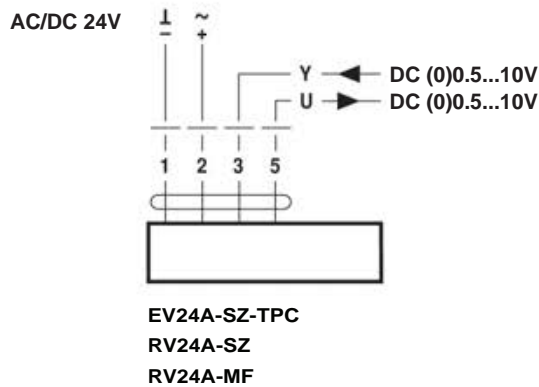
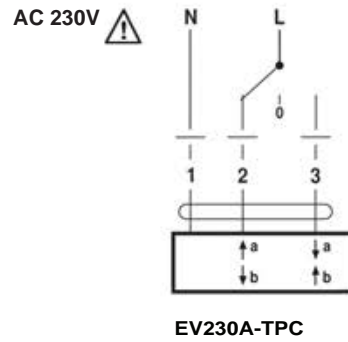
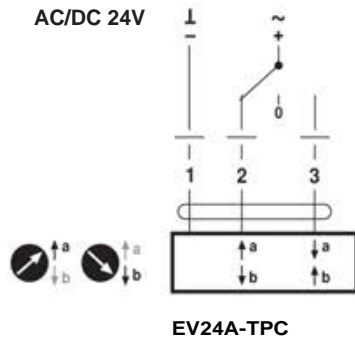
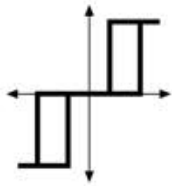
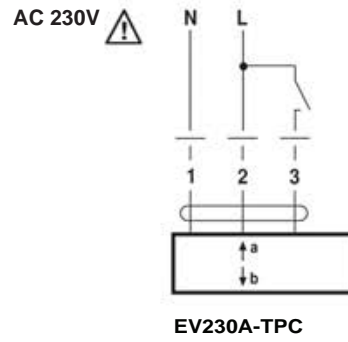
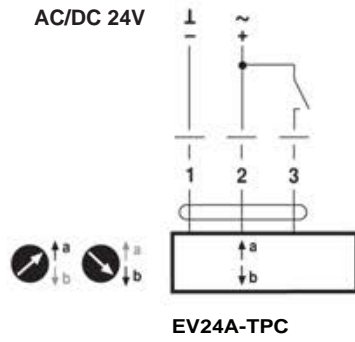

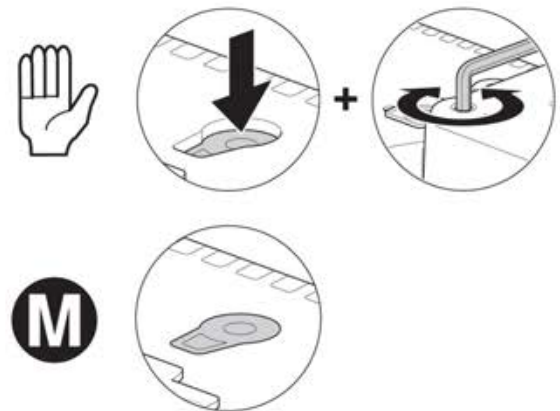
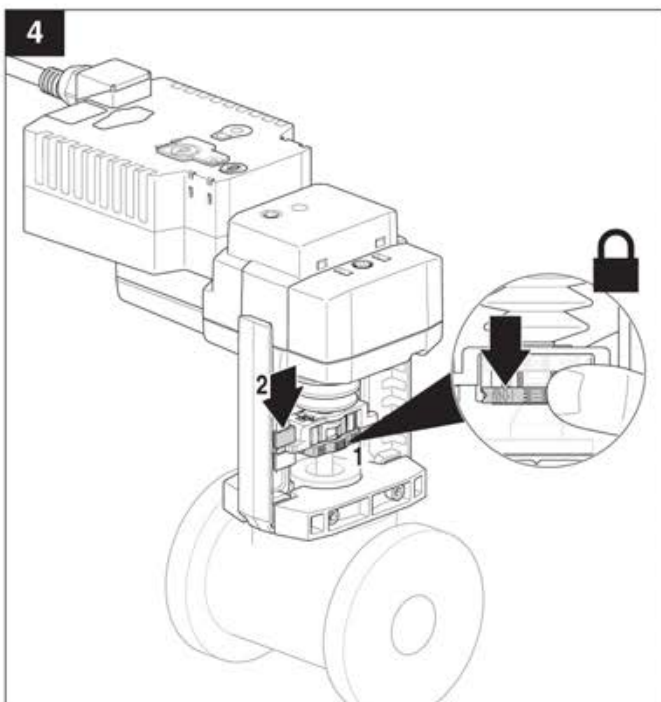
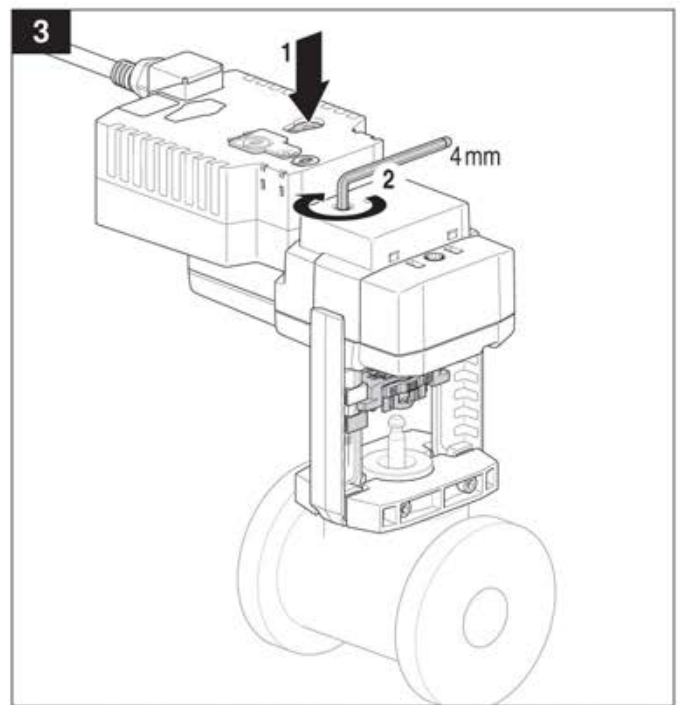
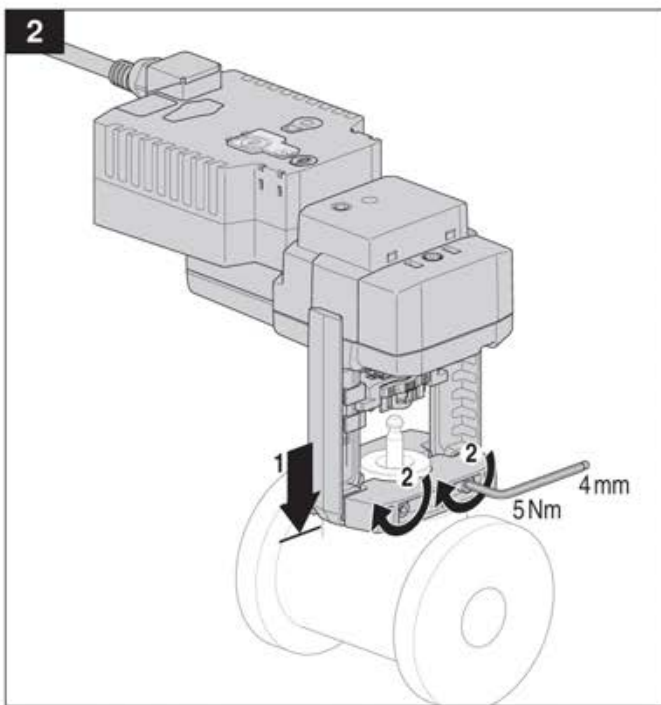
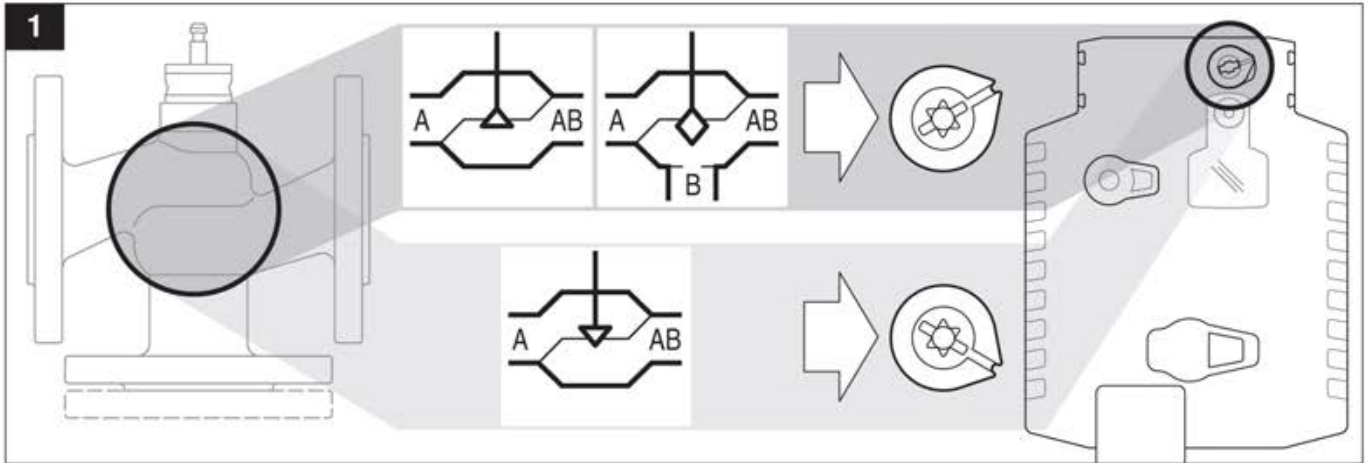

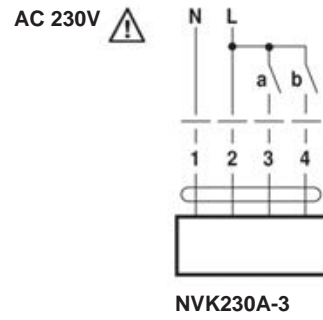
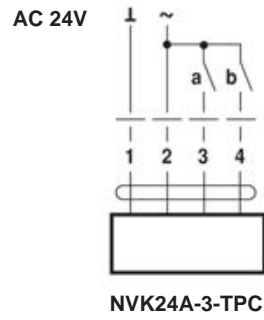
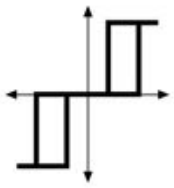

3 a	4 b		

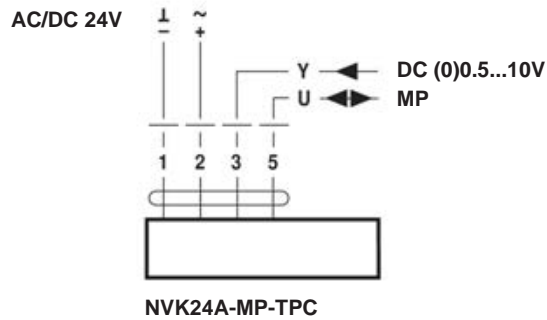

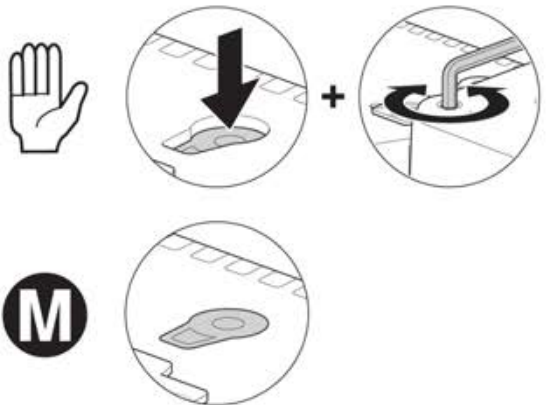
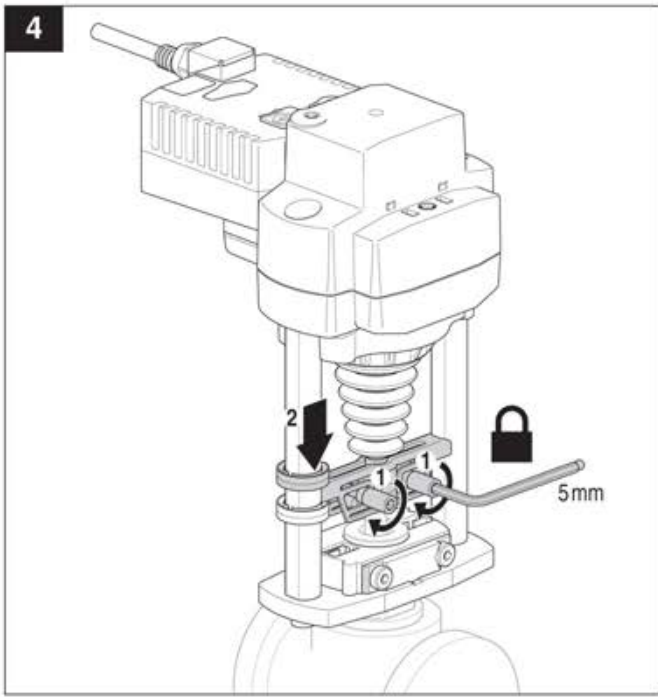
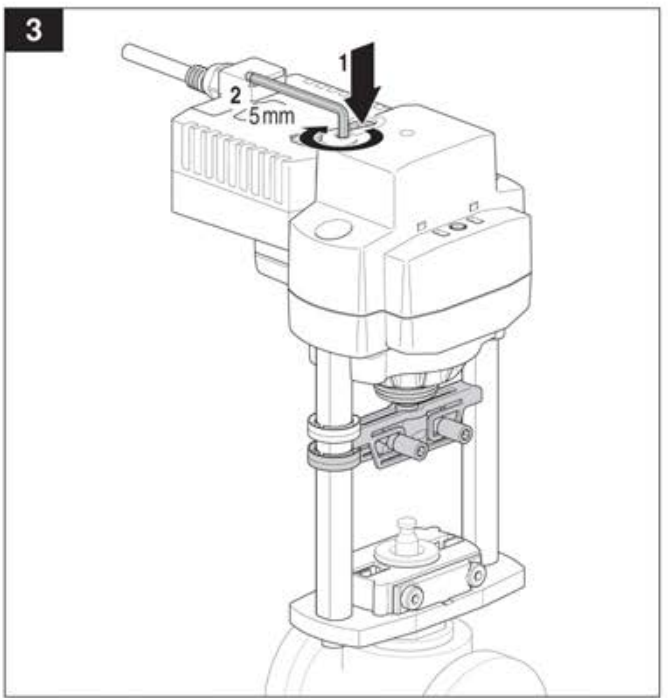
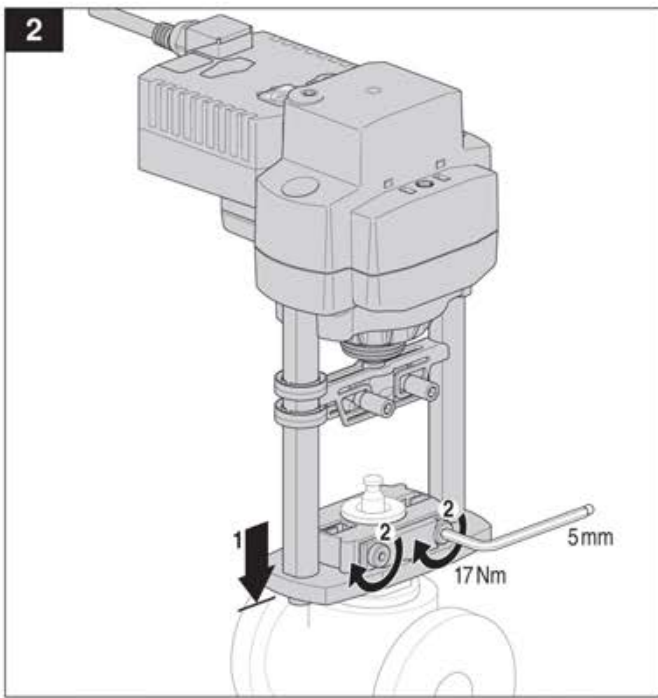
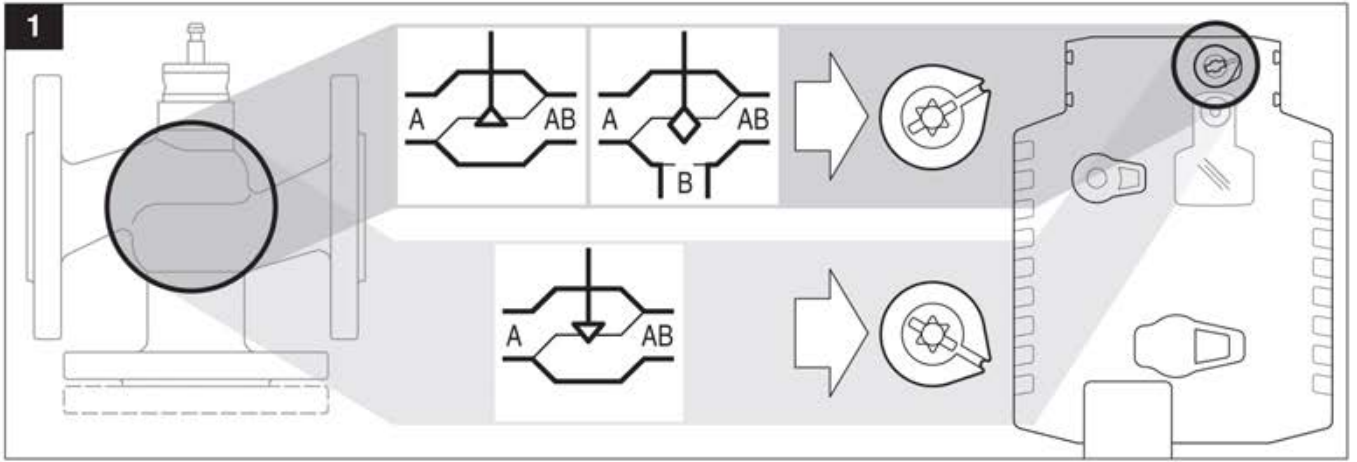

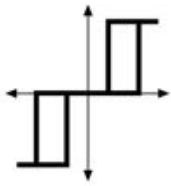

AC 24V

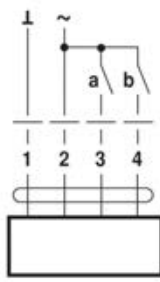

AVK24A-3-TPC

AC 230V

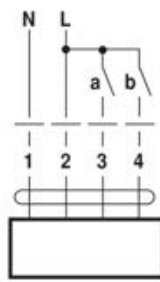

AVK230A-3

3 a	4 b		
		↓	↑
		—	—
		↑	↓
		↓	↑



AC/DC 24V

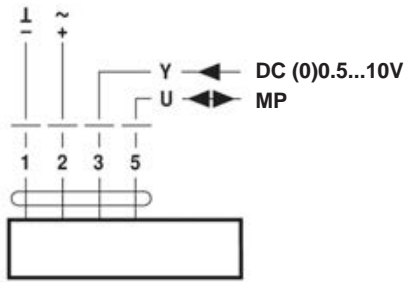

AVK24A-MP-TPC

ASIA PACIFIC HEADQUARTERS

Belimo Actuators Ltd.
Room 207, 2/F, New Commerce Centre
19 On Sum Street, Shatin, N.T.
Hong Kong
Tel: +852 2687 1716
Fax: +852 2687 1795
E-mail: info.asiapacific@belimo.ch

Belimo AUSTRALIA**Melbourne Office:**

Belimo Actuators Pty. Ltd.
12 Enterprise Court
Mulgrave Business Park
Mulgrave, VIC 3170, Australia
Tel: +61-(0)3-8585 7800
Fax: +61-(0)3-8585 7811
E-mail: info.australia@belimo.ch

Sydney Office:

Belimo Actuators Pty. Ltd.
Suite 2.20, 32 Delhi Road
North Ryde, NSW 2113, Australia
Tel: +61 (0)2 9805 1777
Fax: +61 (0)2 9805 1722
E-mail: info.australia@belimo.ch

Belimo CHINA**Shanghai Office:**

Belimo Actuators (Shanghai) Trading Ltd.
479 Chun Dong Road, Building C-2
Xin Zhuang Industry Park
Shanghai 201108, P.R. China
Tel: +86 21 5483 2929
Fax: +86 21 5483 2930
E-mail: info.shanghai@belimo.ch

Beijing Office:

Belimo Actuators Ltd.
Unit 1528-1530, 15F, Tower A,
Jiatai International Mansion,
No. 41, Middle East Fourth Ring Road,
Chaoyang District, Beijing, 100025, P.R. China
Tel: +86 10 6462 1382/1386
Fax: +86 10 6462 1383
E-mail: info.beijing@belimo.ch

Chongqing Office:

Belimo Actuators Ltd.
Room 4, 9th floor, Unit 7, Luoma Jiari Gardan
No. 36, Qing Ling Road, Nan'an District
Chongqing 400060, P.R. China
Tel: +86 23 6275 3155
Fax: +86 23 6280 3380 *519
E-mail: info.chongqing@belimo.ch

Guangzhou Office:

Belimo Actuators Ltd.
Room 1202, Skyline Plaza
644 Tong Fu East Road, Haizhu Area
Guangzhou 510240, P.R. China
Tel: +86 20 3435 1860
Fax: +86 20 3435 1870
E-mail: info.guangzhou@belimo.ch

Belimo HONG KONG**Hong Kong Office:**

Belimo Actuators Ltd.
Room 207, 2/F, New Commerce Centre
19 On Sum Street, Shatin, N.T.
Hong Kong
Tel: +852 2687 1716
Fax: +852 2687 1795
E-mail: info.hongkong@belimo.ch

Indonesia Office:

Belimo Actuators Ltd.
Graha Kencana Building 8th Floor Block B
Jl. Raya Perjuangan 88
Kebon Jeruk - Jakarta Barat 11530
Indonesia
Tel: +62 21 5367 8278
Fax: +62 21 5366 0688
E-mail: info.indonesia@belimo.ch

Japan Office:

Belimo Actuators Ltd.
7th Floor, Honjo-Azumabashi DJ Building
4-19-3, Honjo, Sumida-ku
Tokyo 130-0004, Japan
Tel: +81-3-6823-6961
Fax: +81-3-3626-3911
E-mail: info.japan@belimo.ch

Malaysia Office:

Belimo Actuators Ltd
S-13-12, First Subang,
Jalan SS15/4G,
47500 Subang Jaya,
Selangor, Malaysia.
Tel: +03-56125833
Fax: +03-56125233
E-mail: info.malaysia@belimo.ch

Singapore Office

Belimo Actuators Ltd.
1 Tannery Road #08-04
One Tannery, Singapore 347719
Tel: +65 6842 1626
Fax: +65 6842 1630
E-mail: info.singapore@belimo.ch

Taiwan Office:

Belimo Actuators Ltd.
7F-2, No.343,
Jhonghe Road, Yonghe City,
Taipei County 234, Taiwan
Tel: +886 2 2922 8805
Fax: +886 2 2922 8806
E-mail: info.taiwan@belimo.ch

Thailand Office:

Belimo Actuators Ltd.
90/2 Pensiri Place
Soi Phaholyothin 32,
Phaholyothin Road,
Chandrasek, Jatujak
Bangkok 10900, Thailand
Tel: +662 9415582-3
Fax: +662 9415584
E-mail: info.thailand@belimo.ch

Belimo INDIA**Mumbai Office:**

Belimo Actuators India Pvt. Ltd.
23/ ABCD, Govt. Industrial Estate
Charkop, Kandivali West
Mumbai 400067, India
Tel: +91 22 4025 4800
Fax: +91 22 4025 4899
E-mail: info.india@belimo.ch

Bangalore office:

Belimo Actuators India Pvt. Ltd.
Sreerama Complex,
No. 13, 2nd Floor, 5th Cross Road,
6th Block, Koramangala,
Bangalore – 560097, India
Tel: +91-80-40906311
Fax: +91-80-40906288
E-mail: info.india@belimo.ch

New Delhi Office:

Belimo Actuators India Pvt. Ltd.
Flat No. 515, DLF Tower – B
Jasola Distt. Centre, Jasola
New Delhi 110025, India
Tel: +91 11 41078501
Fax: +91 11 41078508
E-mail: info.india@belimo.ch

Chennai Office:

Belimo Actuators India Pvt. Ltd.
Flat no.3B, Urmilla House
#15, ARK Colony, Eldams Road
Chennai-600 018, India
Tel: +91 44 24355154/5153
E-mail: info.india@belimo.ch

FIRE &
SMOKE



DAMPER



PICCV
EPIV
EV



CCV



BUTTERFLY
VALVE



GLOBE
VALVE



Innovation, Quality and Consultancy:

A partnership for motorising HVAC actuators



5 year warranty



On site around the globe



A complete range of
products from one source



Tested quality



Short delivery
times



Comprehensive
support

Belimo regional head offices

EU BELIMO Automation AG
Brunnenbachstrasse 1
8340 Hinwil, Switzerland
Tel: +41 43 843 61 11
Fax: +41 43 843 62 68
E-mail: info@belimo.ch

AP Belimo Actuators Ltd.
Room 207, 2/F, New Commerce Centre
19 On Sum Street, Shatin, N.T., Hong Kong
Tel: +852 2687 1716
Fax: +852 2687 1795
E-mail: info.asiapacific@belimo.ch

US BELIMO Aircontrol (USA), Inc.
43 Old Ridgebury Road
Danbury, CT 06813-2928
USA
Tel: +800 543-9038 / 203 791-9915
Fax: +800 228-8283 / 203 791-9919

Or contact your nearest Sales Representative

www.belimo.com

